

Branch & Corner Unit Channels - MOD125

Branch Unit Channels

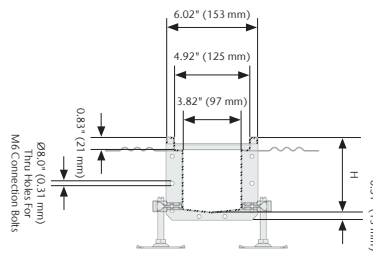
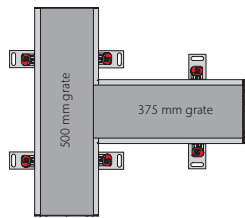
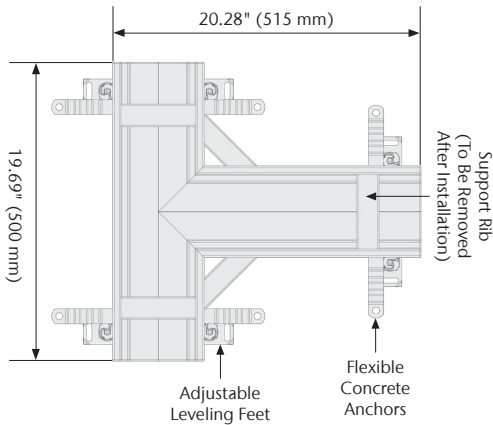

Specification Clause

ACO Modular 125 branch and corner unit channels. Overall height varies, see tables. Channels made from 16ga (1.5mm) AISI 304 or AISI 316L, pickle passivated finish. All channels provided with NBR seal and connection bolts on one side. Multiple grate options available.

ACO recommends checking local plumbing codes prior to installation.

Corner Unit Channels

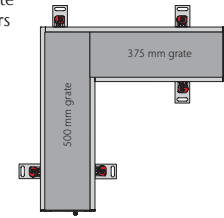
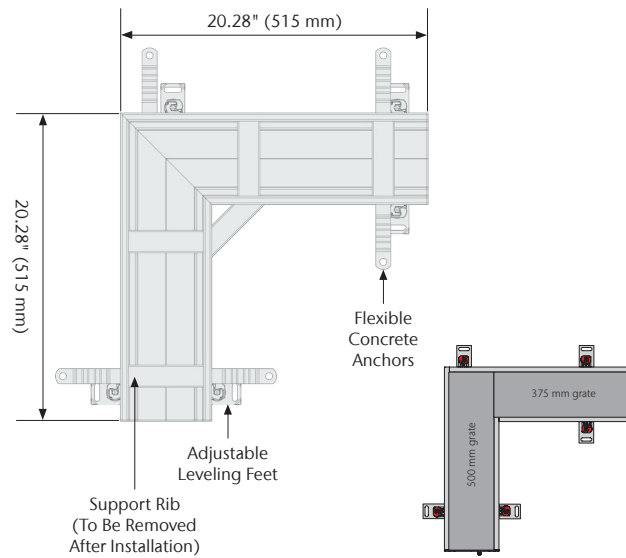

Parts	Part No.	Material	Height (H) in (mm)	Weight (lbs)
Branch Unit Channels	409824	AISI 304	1.97 (50)	8.6
	409825	AISI 304	2.56 (65)	9.2
	409826	AISI 304	3.15 (80)	10.1
	409827	AISI 304	3.74 (95)	10.8
	409828	AISI 304	4.33 (110)	11.7
	409829	AISI 304	4.92 (125)	12.1
	409830	AISI 316L	1.97 (50)	8.6
	409831	AISI 316L	2.56 (65)	9.2
	409832	AISI 316L	3.15 (80)	10.1
	409833	AISI 316L	3.74 (95)	10.8
409834	AISI 316L	4.33 (110)	11.7	
409835	AISI 316L	4.92 (125)	12.1	

Parts	Part No.	Material	Height (H) in (mm)	Weight (lbs)
Corner Unit Channels	409812	AISI 304	1.97 (50)	8.6
	409813	AISI 304	2.56 (65)	9.2
	409814	AISI 304	3.15 (80)	10.1
	409815	AISI 304	3.74 (95)	10.8
	409816	AISI 304	4.33 (110)	11.7
	409817	AISI 304	4.92 (125)	12.1
	409818	AISI 316L	1.97 (50)	8.6
	409819	AISI 316L	2.56 (65)	9.2
	409820	AISI 316L	3.15 (80)	10.1
	409821	AISI 316L	3.74 (95)	10.8
409822	AISI 316L	4.33 (110)	11.7	
409823	AISI 316L	4.92 (125)	12.1	

ACO, Inc.

West Sales Office
825 W. Beechcraft Street
Casa Grande, AZ 85122
Tel: (520) 421-9988
Toll-Free: (888) 490-9552
Fax: (520) 421-9899

Northeast Sales Office
9470 Pinecone Drive
Mentor, OH 44060
Tel: (440) 639-7230
Toll-Free: (800) 543-4764
Fax: (440) 639-7235

Southeast Sales Office
4211 Pleasant Road
Fort Mill, SC 29708
Toll-Free: (800) 543-4764
Fax: (803) 802-1063

info@acousa.com
www.acousa.com

© November 2021 ACO, Inc.

All reasonable care has been taken in compiling the information in this document. All recommendations and suggestions on the use of ACO products are made without guarantee since the conditions of use are beyond the control of the company. It is the customer's responsibility to ensure that each product is fit for its intended purpose and that the actual conditions of use are suitable. ACO, Inc. reserves the right to change products and specifications without notice.

ACO. creating the future of drainage



ACO Specification Information