

Pipe - Branch Long Sweep Tee

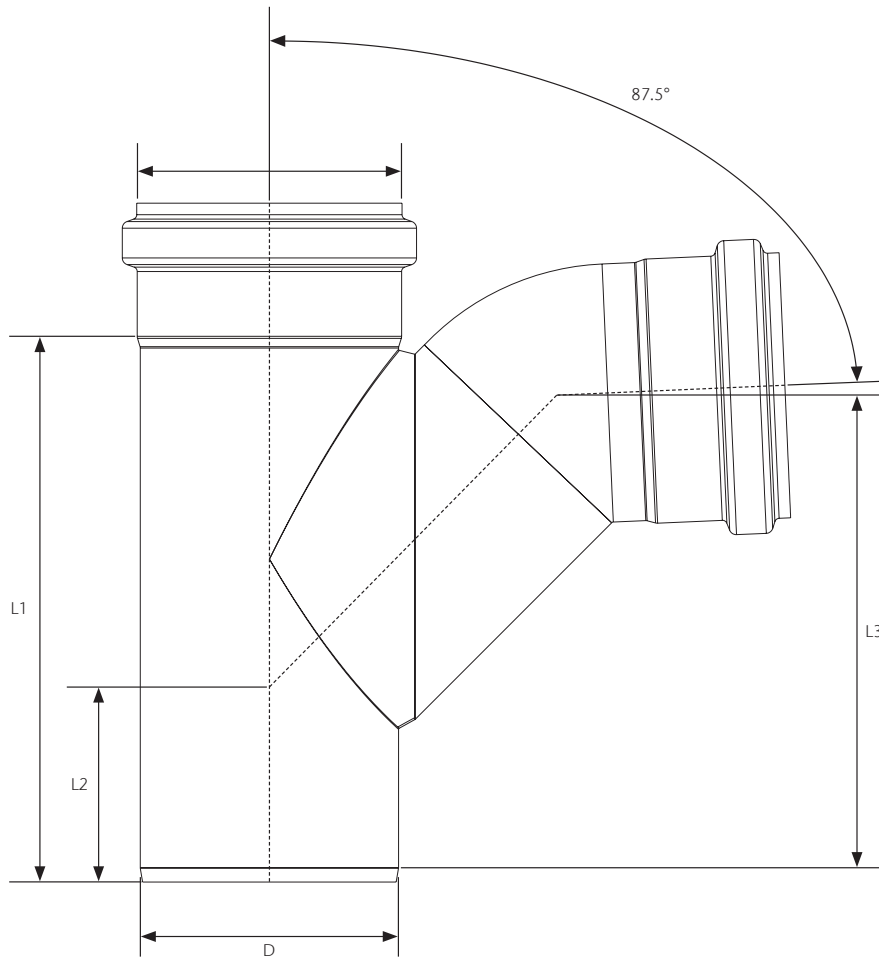
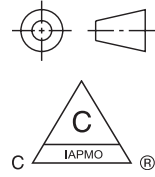

Specifications

General

Used with ACO Pipe System. Made from AISI 316L. Resistant to thermal and dynamic shocks. Rodent-proof and sag-proof. Non-combustible. Double-lipped seal push-fit connection. Designed for gravity piping system with maximum working pressure of 0.5 bar. Socket clamps, NBR and FPM gasket material also available upon request. Socket clamp can increase maximum operating pressure to 0.7 bar. ACO recommends checking local plumbing codes prior to installation. Manufactured to EN 1124-1 and 1124-2.

Part No.	Length (L1) in (mm)	Length (L2) in (mm)	Length (L3) in (mm)	Diameter (D) in (mm)	Gasket Material	Pipe Material	Weight lbs
417380	4.53 (115)	2.17 (55)	4.14 (105)	1.57 (40)	EPDM	316L	0.8
98864	5.04 (128)	2.25 (57)	4.61 (117)	1.97 (50)	EPDM	316L	0.8
98866	7.05 (179)	2.92 (74)	6.19 (157)	2.95 (75)	EPDM	316L	1.7
98868	9.18 (233)	3.47 (88)	8.23 (209)	4.33 (110)	EPDM	316L	3.1
98870	13.08 (332)	7.25 (184)	11.89 (302)	6.30 (160)	EPDM	316L	8.3

ACO, Inc.

West Sales Office info@acousa.com
 825 W. Beechcraft Street www.acousa.com
 Casa Grande, AZ 85122 www.acobuildingdrainage.us
 Tel: (520) 421-9988
 Toll-Free: (888) 490-9552
 Fax: (520) 421-9899

© February 2022 ACO, Inc.
 All reasonable care has been taken in compiling the information in this document. All recommendations and suggestions on the use of ACO products are made without guarantee since the conditions of use are beyond the control of the company. It is the customer's responsibility to ensure that each product is fit for its intended purpose and that the actual conditions of use are suitable. ACO, Inc. reserves the right to change products and specifications without notice.

ACO. creating
the future of drainage



ACO Specification Information