

Product Features

- Certified to EN 1433 Load Class C - 56,000 lbs - 1,162 psi
- Uses 'QuickLok' boltless locking system
- Suitable for use with K300, KS300, H300K-13, and H300KS-13 channels
- Manufactured from 16 gauge galvanized steel
- Complies with ADA - American Disabilities Act of 1990 Section 4.5.4
- Bicycle Tire Penetration Resistant to AS 3996 - 2006
- Complies with ASME: A112.6.3 - 2001: Section 7.12 Heel Resistant Strainers and Grates

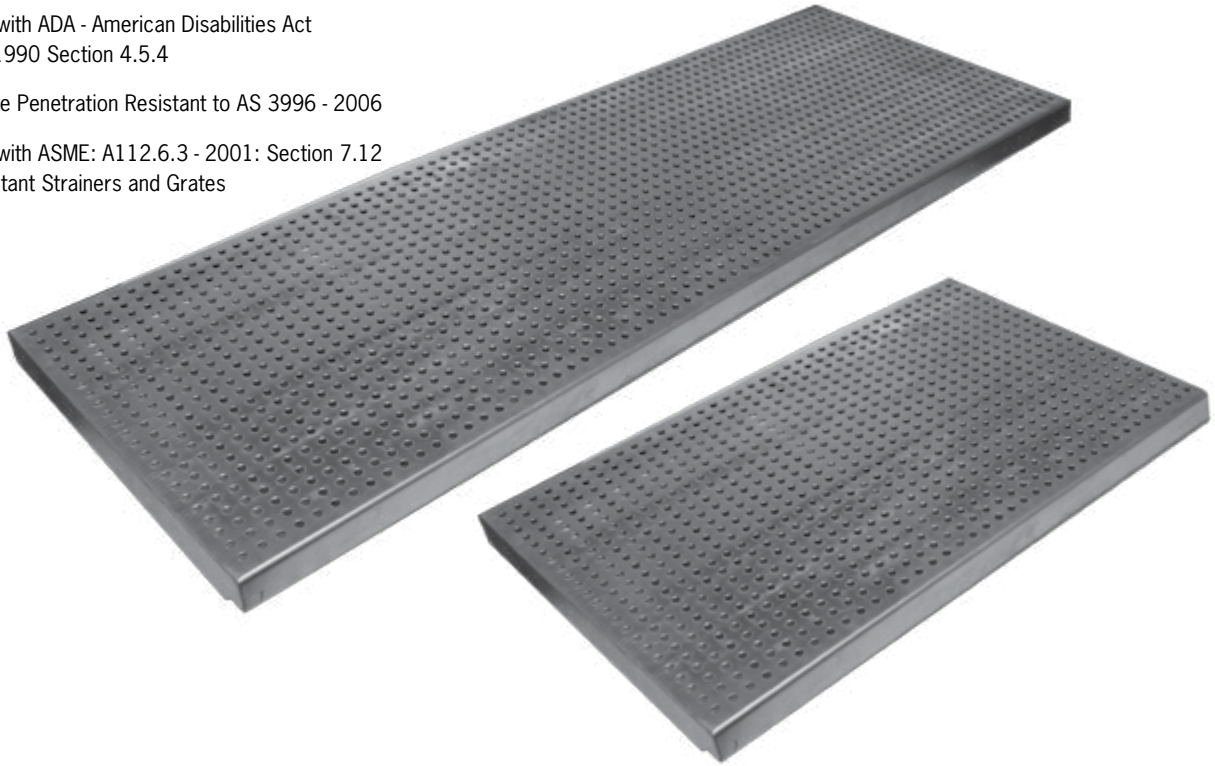

Specifications

General

The surface drainage system shall be ACO Drain K300, KS300, H300K-13, and H300KS-13, channels* complete with ACO Type 811Q/813Q longitudinal (ADA compliant) galvanized steel grate with 'QuickLok' locking as manufactured by ACO Polymer Products, Inc. or similar approved.

Materials

The covers shall be manufactured from galvanized steel and have **minimum** properties as follows:

- **Independently certified to meet Load Class C to EN 1433 - 56,000 lbs - 1,162 psi**
- **16 gauge galvanized steel**
- **Intake area of 31.9 sq. in. (205.81 cm²) per half meter of grate/64.8 sq. in. (418.06 cm²) per meter grate**

The overall width of 13.35" (339mm) and overall length of 39.37" (1000mm) (Type 811Q) and overall length of 19.69" (500mm) (Type 813Q). Perforations measure 0.25" (6.4mm) in diameter.

Installation

The trench drain system and grates shall be installed in accordance with the manufacturer's installation instructions and recommendations.

* delete as appropriate

ACO Specification Information

ACO DRAIN

Type 811Q/813Q Perforated galvanized steel grate

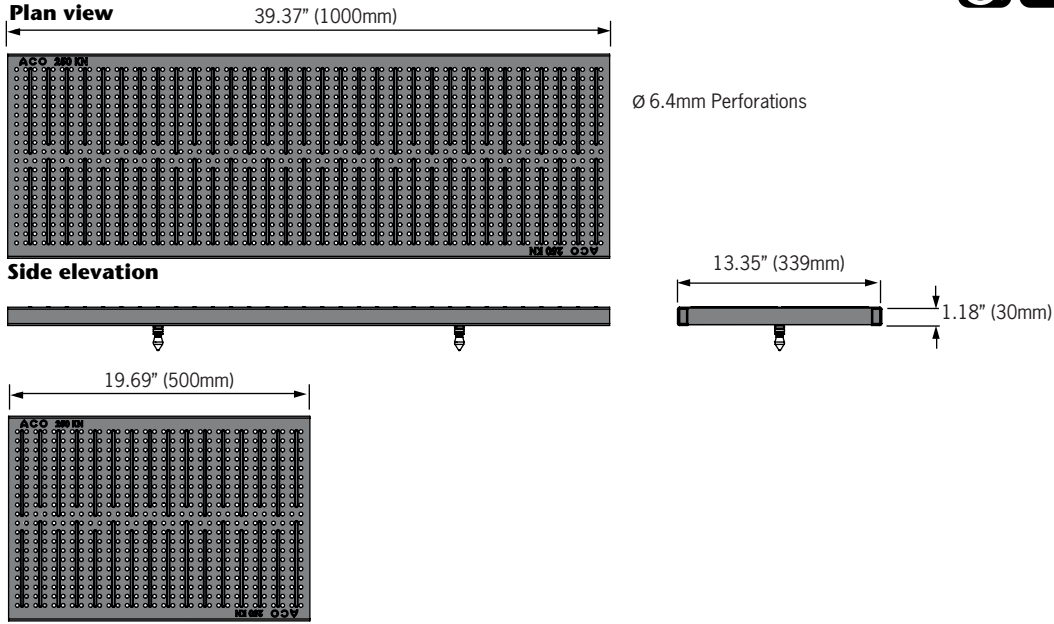

Description	Part No.	Length inches (mm)	Width inches (mm)	Weight lbs.
QuickLok grate				
Type 811Q Perforated galvanized steel grate	98967	39.37 (1000)	13.35 (339)	30.9
Type 813Q Perforated galvanized steel grate	98966	19.69 (500)	13.35 (339)	15.0
QuickLok locking bar	10458	-	-	0.5
QuickLok grate removal tool	01318	-	-	0.3

'QuickLok' locking mechanism

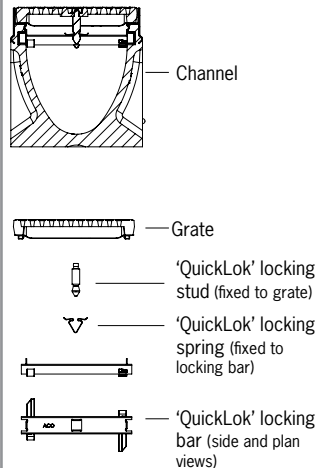

ACO 'QuickLok' is a patented boltless locking system, grates are removed and replaced with the minimum time and effort for ease of maintenance. The unique design provides a positive 'snap down' fit into the locking bar. A stud is fixed to the grate which 'locks' into the spring clip in the locking bar.

The 'QuickLok' stud is made from stainless steel and high density nylon, the locking bar and clip are stainless steel, for use in both general purpose and corrosive environments.

ACO Specification Information

ACO Polymer Products, Inc.

Northeast Sales Office

9470 Pinecone Drive
Mentor, Ohio 44060
Tel: (440) 639-7230
Toll free: (800) 543-4764
Fax: (440) 639-7235

West Sales Office

P.O. Box 12067
Casa Grande, AZ 85130
Tel: (520) 421-9988
Toll Free: (888) 490-9552
Fax: (520) 421-9899

Southeast Sales Office

4211 Pleasant Road
Fort Mill, SC 29708
Toll free: (800) 543-4764
Fax: (803) 802-1063

Follow us on



Electronic Contact:

info@ACODrain.us
www.ACODrain.us



© August 2015 ACO Polymer Products, Inc. This information is believed to be accurate but it is not guaranteed to be so. We cannot assume liability for results that buyer obtains with our product since conditions of use are beyond the control of the company. It is the customer's responsibility to evaluate suitability and safety of product for his own use. ACO Polymer Products Inc. reserves the right to change the product and specifications without notice.