

# TrafficDrain TD300-U / TD3U Galvanized

## One meter channel

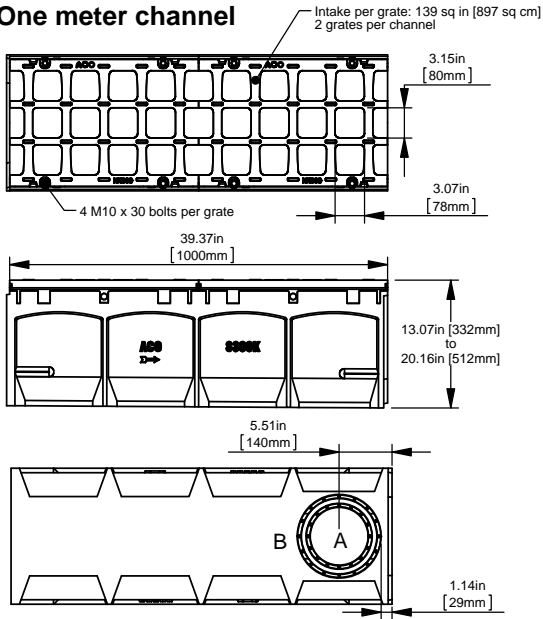

## Half meter channel

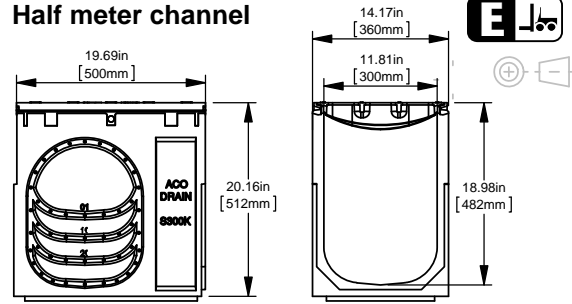

## In-line catch basin - with 612 short base

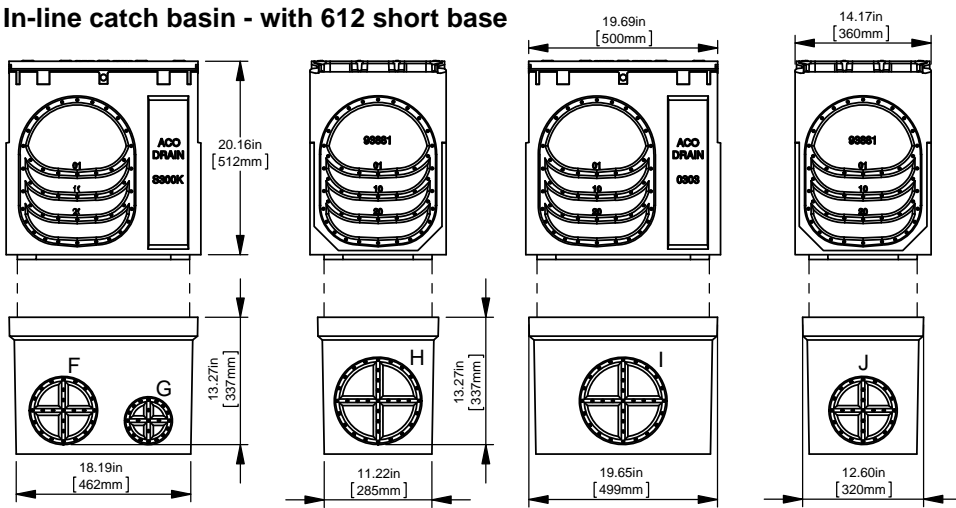

## End Cap

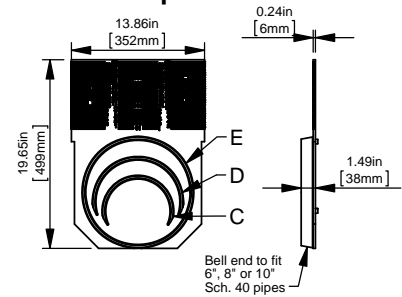

## Outlet flow rates

Outlet	Product	Outlet size (Sch. 40)	Invert Depth (in)	GPM	CFS
A	Bottom outlet - TD3U-G-00	6" round	11.89	426	0.94
A	Bottom outlet - TD3U-G-030	6" round	18.89	533	1.18
B	Bottom outlet - TD3U-G-00	8" round	11.89	758	1.68
B	Bottom outlet - TD3U-G-030	8" round	18.98	948	2.11
C	Outlet cap - TD3U-G-00	6" round	11.89	370	0.82
C	Outlet cap - TD3U-G-030	6" round	18.98	489	1.08
D	Outlet cap - TD3U-G-5	8" round	13.07	656	1.46
D	Outlet cap - TD3U-G-030	8" round	18.98	842	1.87
E	Outlet cap - TD3U-G-13	10" round	14.96	1073	2.39
E	Outlet cap - TD3U-G-030	10" round	18.98	1271	2.83
F	TD3-900 - 612"	6" round	33.43	673	1.50
G	TD3-900 - 612"	4" round	33.43	304	0.68
H	TD3-900 - 612"	8" round	33.43	1177	2.62
I	TD3-900 - 612"	8" round	33.43	1177	2.62
J	TD3-900 - 612"	6" round	33.43	673	1.50
K	TD3-900 - 614"	6" round	33.15	560	1.25
L	TD3-900 - 614"	6" round	47.33	810	1.80
M	TD3-900 - 614"	4" round	47.33	360	0.80
N	TD3-900 - 614"	4" round	31.77	298	0.66
O	TD3-900 - 614"	8" round	47.33	1417	3.16
P	TD3-900 - 614"	6" round	33.15	560	1.25
Q	TD3-900 - 614"	8" round	47.33	1417	3.16
R	TD3-900 - 614"	4" round	32.16	298	0.66
S	TD3-900 - 614"	6" round	47.33	810	1.80

Note: These are pipe flows are the specific outlet, NOT channel flow rates.  
\*Catch basin flow rates are without trash bucket - using trash bucket reduces flow.

www.ACOInfrastructure.us

ACO Specification Information



**ACO Infrastructure**  
**TrafficDrain TD300-U / TD3U Galvanized**

**614 deep base**

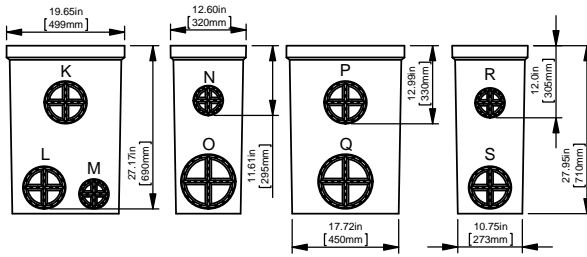

Total capacity of in-line catch basin with 612 base = 27.0 gallons  
 Total capacity of in-line catch basin with 614 base = 36.0 gallons

TD3U-00 Neutral channel Galvanized 39.37" (1m)	96962G	11.89	302	207.5
TD3U-1 Sloped channel Galvanized 39.37" (1m)	96963G	12.13	308	208.1
TD3U-2 Sloped channel Galvanized 39.37" (1m)	96964G	12.36	314	209.4
TD3U-3 Sloped channel Galvanized 39.37" (1m)	96965G	12.60	320	210.8
TD3U-4 Sloped channel Galvanized 39.37" (1m)	96966G	12.83	326	212.1
TD3U-5 Sloped channel Galvanized 39.37" (1m)	96967G	13.07	332	213.4
TD3U-6 Sloped channel Galvanized 39.37" (1m)	96968G	13.31	338	214.7
TD3U-7 Sloped channel Galvanized 39.37" (1m)	96969G	13.54	344	216.1
TD3U-8 Sloped channel Galvanized 39.37" (1m)	96970G	13.78	350	217.4
TD3U-9 Sloped channel Galvanized 39.37" (1m)	96971G	14.02	356	218.7
TD3U-10 Sloped channel Galvanized 39.37" (1m)	96972G	14.25	362	220.0
TD3U-010 Neutral channel Galvanized 39.37" (1m)	96973G	14.25	362	220.7
TD3U-11 Sloped channel Galvanized 39.37" (1m)	96975G	14.49	368	221.3
TD3U-12 Sloped channel Galvanized 39.37" (1m)	96976G	14.72	374	222.7
TD3U-13 Sloped channel Galvanized 39.37" (1m)	96977G	14.96	380	224.0
TD3U-14 Sloped channel Galvanized 39.37" (1m)	96978G	15.20	386	225.3
TD3U-15 Sloped channel Galvanized 39.37" (1m)	96979G	15.43	392	226.6
TD3U-16 Sloped channel Galvanized 39.37" (1m)	96980G	15.67	398	228.0
TD3U-17 Sloped channel Galvanized 39.37" (1m)	96981G	15.91	404	229.3
TD3U-18 Sloped channel Galvanized 39.37" (1m)	96982G	16.14	410	230.6
TD3U-19 Sloped channel Galvanized 39.37" (1m)	96983G	16.38	416	231.9
TD3U-20 Sloped channel Galvanized 39.37" (1m)	96984G	16.61	422	233.2
TD3U-020 Neutral channel Galvanized 39.37" (1m)	96985G	16.61	422	234.6
TD3U-21 Sloped channel Galvanized 39.37" (1m)	96987G	16.85	428	234.6
TD3U-22 Sloped channel Galvanized 39.37" (1m)	96988G	17.09	434	235.9
TD3U-23 Sloped channel Galvanized 39.37" (1m)	96989G	17.32	440	237.2
TD3U-24 Sloped channel Galvanized 39.37" (1m)	96990G	17.56	446	238.5
TD3U-25 Sloped channel Galvanized 39.37" (1m)	96991G	17.80	452	239.9
TD3U-26 Sloped channel Galvanized 39.37" (1m)	96992G	18.03	458	241.2
TD3U-27 Sloped channel Galvanized 39.37" (1m)	96993G	18.27	464	242.5
TD3U-28 Sloped channel Galvanized 39.37" (1m)	96994G	18.50	470	243.8
TD3U-29 Sloped channel Galvanized 39.37" (1m)	96995G	18.74	476	245.2
TD3U-30 Sloped channel Galvanized 39.37" (1m)	96996G	18.98	482	246.5
TD3U-030 Neutral channel Galvanized 39.37" (1m)	96997G	18.98	482	249.1
TD3U-0303 Neutral channel Galvanized 19.69" (0.5m)	97013G	18.98	482	141.0
TD3U-900 Catch basin top - 19.69" (0.5m)	96998	-	-	130.0
Type 612 Catch basin base - short	01614	-	-	57.1
Type 614 Catch basin base - deep	05641	-	-	102.3
600 Series plastic trash bucket - short	98653	-	-	2.9
600 Series plastic trash bucket - deep	98665	-	-	3.9
Closing/outlet end cap	98132	-	-	8.0

**Notes:**

- Channels come with preformed 6" & 8" drill-outs on underside of each channel (except for TD3-0303).
- Inverts shown are for the male end; for female invert depth subtract 6mm (~0.24") from the male invert (except for neutral channels, where both inverts are the same).
- To calculate the overall channel depth add 30mm (~1.18") to invert depth.
- End cap can be cut down to suit all channel sizes.
- Compliant with TXDOT spec requirements and listed on TXDOT QPL.

**Specifications**

**General**

The surface drainage system shall be ACO TrafficDrain TD300 complete with gratings secured with M10x30 bolts.

**Materials**

The trench system bodies shall be manufactured from polyester polymer concrete with the minimum properties as follows:

Compressive strength: 14,000 psi  
 Flexural strength: 4,000 psi

Water absorption	0.07%
Frost proof	YES
Salt proof	YES
Dilute acid and alkali resistant	YES

**Grates**

Grates shall be ductile iron to ASTM A536, minimum grade 65-45-12. Grates and rails are from ductile iron, then hot dipped galvanized.

**Installation**

The trench drain system shall be installed in accordance with the manufacturer's installation instructions and recommendations.

The nominal clear opening should be 12" (300mm) with overall width of 14.17" (360mm). Pre-cast units shall be manufactured with either an invert slope of 0.6% or with neutral invert and have a wall thickness of at least 0.67" (16mm). Each unit will feature a male to female interconnecting end profile. Units shall have horizontal cast in anchoring keys on the outside wall to ensure maximum mechanical bond to the surrounding bedding material and pavement surface. The ductile iron edge rail will be integrally cast in by the manufacturer to ensure maximum homogeneity between polymer concrete body and edge rail. Each edge rail shall be at least 1/4" (6mm) thick.

**ACO, Inc.**

**Northeast Sales Office**  
 9470 Pinecone Dr.  
 Mentor, OH 44060  
 Tel: (440) 639-7230  
 Toll Free: (800) 543-4764  
 Fax: (440) 639-7235

**West Sales Office**  
 825 West Beechcraft St.  
 Casa Grande, AZ 85122  
 Tel: (520) 421-9988  
 Toll Free: (888) 490-9552  
 Fax: (520) 421-9899

**Southwest Sales Office**  
 4211 Pleasant Road.  
 Fort Mill, SC 29708  
 Tel: (800) 543-4764  
 Fax: (803) 802-1063

**Follow us on**



**Electronic Contract:**  
 info@ACODrain.us  
 www.ACODrain.us