

# Oleotop NS60 Light Oil Separator

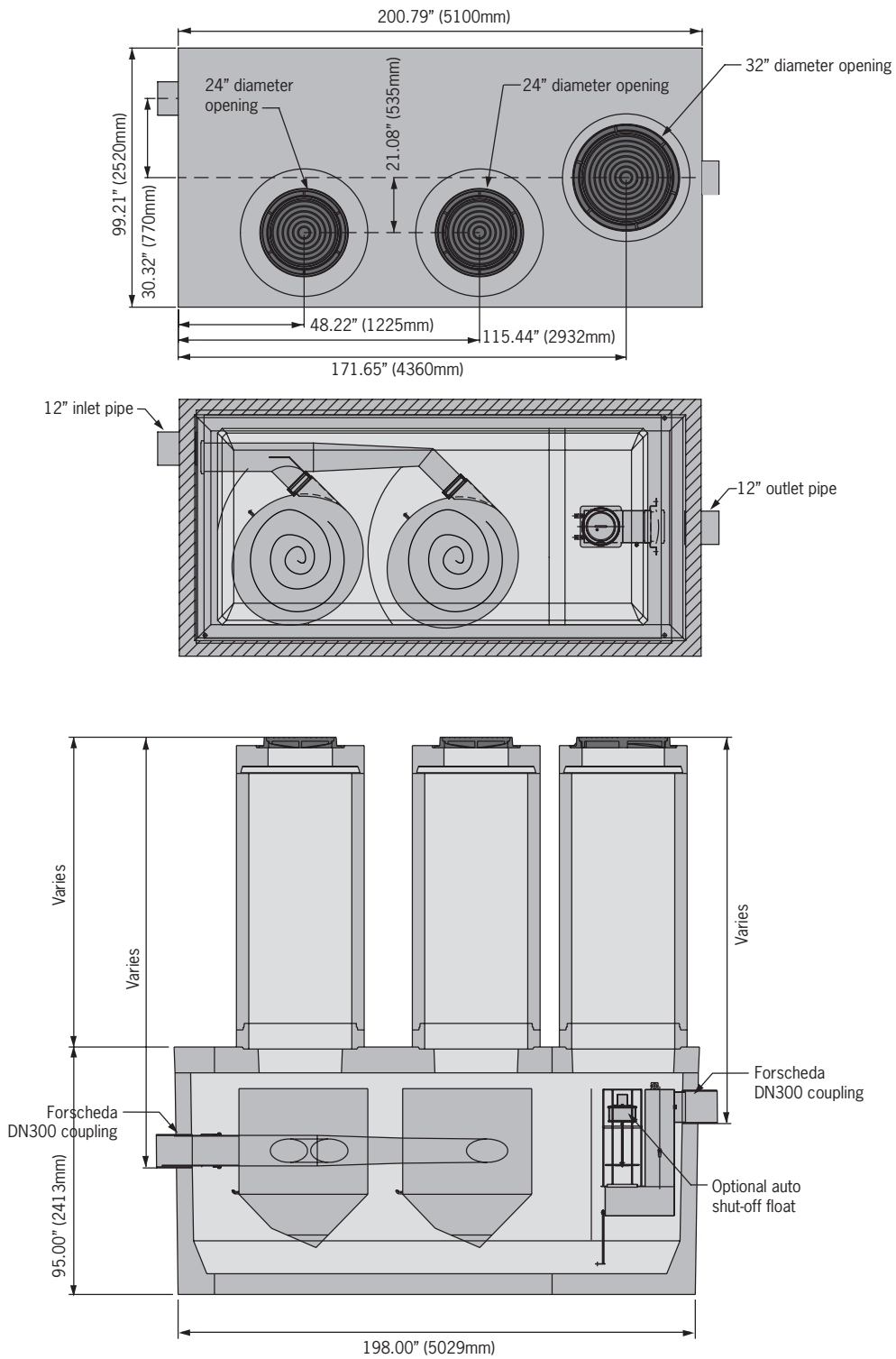

*ACO Specification Information*

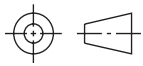

**ACO ENVIRONMENTAL**

**Oleotop NS60 Light Oil Separator**

Separator Size	Flow GPM (l/s)	External Dims (inches)	Pipe Size (inches)	Manhole Cover Dia (inches)	Oil Storage Capacity (Gallons)	Sludge Trap (Gallons)	Weight tons
NS60	15.84 (60)	198.00L x 99.21W	12	24/32	829.5	710	28.7*

\*Excludes three concrete access shafts and manhole covers

**Specifications**

**General**

The separator element of the bypass separator system shall be ACO Environment Oleopator NS60 Light Oil Separator as manufactured by ACO Polymer Products, Inc. or equal approved.

**Materials**

The separator body shall be manufactured from cement concrete, with minimum properties as follows:

Compressive strength: 4,500 psi  
 Flexural strength: 587 psi  
 Interior surfaces of the separator shall be epoxy coated.

The nominal body dimensions shall be 198" (5030mm) long with overall width of 99.21" (2520mm) and overall height of 217" (5512mm). Units shall be manufactured with a wall thickness of at least 6" (150mm). The body shall be manufactured with 12.00" (300mm) diameter inlet and outlet pipes and shall offer up to 711 gallons of sludge and 1120 gallons of oil capacity. Oil shall be removed from the inflowing water in accordance with EN 858 Class 1 requirements of effluent quality of 5 parts per million (ppm).

An optional alarm system is available to provide audio, visual and/or SMS alerts to ensure maintenance can be carried out before the separator system fails. Required for compliance with UL 2215.

**Access Cover**

A solid cast iron covers of 24.00" (600mm) and 32.00" (800mm) diameter and frame are supplied to provide access into the sludge chamber for maintenance. Complies with AASHTO M306-05.

**Installation**

The separator system shall be installed in accordance with the manufacturer's installation instructions and recommendations.

The Oleopator NS60 Light Oil Separator can be used as part of a bypass separator system. For information on the additional units please contact ACO

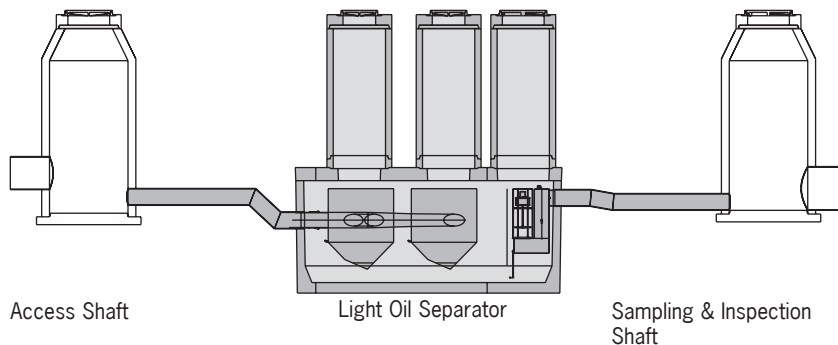

**ACO Polymer Products, Inc.**

**East Sales Office**  
 P.O. Box 245  
 Chardon, OH 44024  
 Tel: (440) 285-7000  
 Toll free: (800) 543-4764  
 Fax: (440) 285-7005

**West Sales Office**  
 P.O. Box 12067  
 Casa Grande, AZ 85230  
 Tel: (520) 421-9988  
 Toll Free: (888) 490-9552  
 Fax: (520) 421-9899



**Electronic Contact:**  
 info@acousa.com  
 www.acousa.com

