

MiniKlassik - Type 247D Longitudinal Stainless Steel Grate

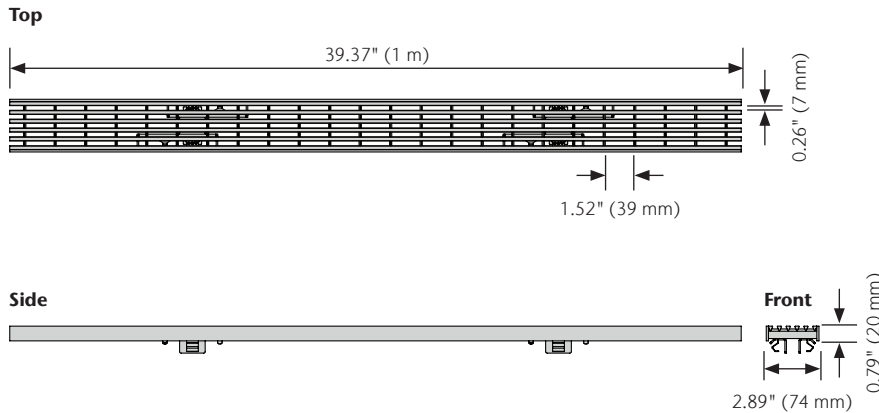
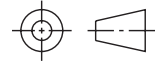

Specifications

General

The surface drainage system shall be ACO Drain MiniKlassik KS50 channels complete with ACO Type 247D MiniKlassik longitudinal stainless steel grate as manufactured by ACO, Inc. or similar approved.

Materials

The covers shall be manufactured from stainless steel and have minimum properties as follows:

- Independently certified to meet EN 1433 Load Class B - 28,000 lbs - 581 psi
- 14 gauge, grade 304 stainless steel
- Intake area of 48.2 in² (311 cm²)/m grate

The overall width of 2.89" (74 mm) and overall length of 39.37" (1 m). Slots measure 1.52" (39 mm) by 0.26" (7 mm).

Installation

The trench drain system and grates shall be installed in accordance with the manufacturer's installation instructions and recommendations.

DrainLok Locking Mechanism

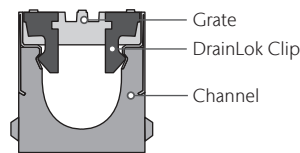

ACO DrainLok is a patented, boltless locking system that removes the need for bolts and bars while improving the hydraulic capacity of the channel. DrainLok Clips lock into the channel's edge rail for rapid installation. ACO DrainLok grates are fitted with an anti-shunt mechanism that restricts unwanted grate movement when installed, improving durability and longevity of the system.

Product Features

- Suitable for use with KS50
- Certified to EN 1433 Load Class B - 28,000 lbs - 581 psi
- Manufactured from 14 gauge, grade 304 stainless steel
- Uses DrainLok boltless locking system
- Complies with ADA - American Disabilities Act of 2010 Section 302.3
- Complies with ASME: A112.6.3 - 2001: Section 7.12 Heel-Resistant Strainers and Grates
- Bicycle Tire Penetration-Resistant to AS3996-2006

	Part #	Length in (mm)	Width in (mm)	Weight lbs
Type 247D Longitudinal Stainless Steel Grate	142436	39.37 (1000)	2.89 (74)	5.9

ACO, Inc.

West Sales Office
825 W. Beechcraft Street
Casa Grande, AZ 85122
Tel: (520) 421-9988
Toll-Free: (888) 490-9552
Fax: (520) 421-9899

Northeast Sales Office
9470 Pinecone Drive
Mentor, OH 44060
Tel: (440) 639-7230
Toll-Free: (800) 543-4764
Fax: (440) 639-7235

Southeast Sales Office
4211 Pleasant Road
Fort Mill, SC 29708
Toll-Free: (800) 543-4764
Fax: (803) 802-1063

info@acousa.com
www.acousa.com

© May 2020 ACO, Inc.

All reasonable care has been taken in compiling the information in this document. All recommendations and suggestions on the use of ACO products are made without guarantee since the conditions of use are beyond the control of the company. It is the customer's responsibility to ensure that each product is fit for its intended purpose and that the actual conditions of use are suitable. ACO, Inc. reserves the right to change products and specifications without notice.

ACO. creating
the future of drainage



ACO Specification Information