

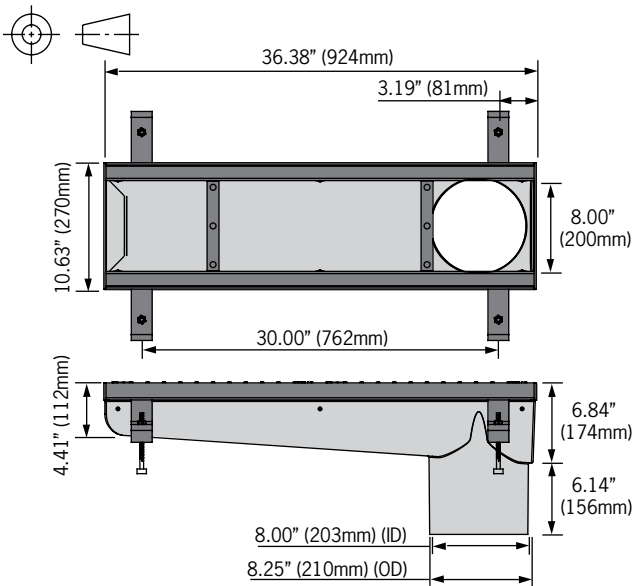

# BridgeDrain - 36" Scupper with black coated frame



### Outlet flow rates

Outlet	Outlet Size	Invert Depth	GPM	CFS
A	8" ID pipe	6.60"	516	1.15

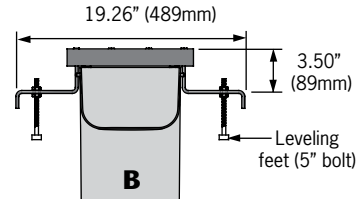

### Specification

#### General

The scupper shall be ACO INFRASTRUCTURE BridgeDrain Scuppers as manufactured by ACO, Inc. or equal approved.

#### Materials

The scupper bodies shall be manufactured from polyester fiberglass, with minimum properties as follows:

- Compressive strength: 24,400 psi
- Flexural strength: 9,943 psi
- Water absorption: 0.33%
- Frost proof
- Salt proof - B117 Salt Spray Test compliant
- Dilute acid and alkali resistant

The nominal clear opening shall be 8.00" (203mm) with overall width of 10.63" (270mm). Units shall be manufactured with a sloped invert and have a wall thickness of at least 0.125" (3mm) Each unit will feature a 8" outlet pipe. The fiberglass channel body shall be fixed to the frame using push fit nylon studs. Overall length shall be 36.38".

Frames shall be manufactured from either minimum 0.188" (5mm) thick black powder coated steel and incorporate levelling feet to ensure correct and easy installation; leveling feet also act as concrete anchors to ensure maximum mechanical bond to surrounding bedding material and pavement surface.

#### Grates

See separate ACO Spec Info sheets for details.

#### Installation

The surface drain system shall be installed in accordance with the manufacturer's installation instructions and drawings.

### BridgeDrain Scupper - Part List

Description	Part No	Length		Invert Depth - female		Invert Depth - male		Weight lbs
		inches	mm	inches	mm	inches	mm	
<b>Scuppers</b>								
36" scupper with black frame	95348	36.38	924	4.30	109	6.60	167	85.0

#### ACO, Inc.

**West Sales Office**  
825 W. Beechcraft St.  
Casa Grande, AZ 85122  
Tel: (520) 421-9988  
Toll Free: (888) 490-9552  
Fax: (520) 421-9899

**Northeast Sales Office**  
9470 Pinecone Dr.  
Mentor, OH 44060  
Tel: (440) 639-7230  
Toll free: (800) 543-4764  
Fax: (440) 639-7235

**Southeast Sales Office**  
4211 Pleasant Road  
Fort Mill, SC 29708  
Tel: (800) 543-4764  
Fax (803) 802-1063



**Electronic Contact:**  
info@acousa.com  
www.acousa.com

© April 2018, ACO, Inc.  
All reasonable care has been taken in compiling this document. All recommendations on the use of ACO products are made without guarantee since the conditions of use are beyond the control of the company. ACO reserves the right to change the product and specifications without notice.



ACO Specification Information