

DK100 System with Type 454D Composite Cover with Microgrip

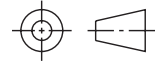

Type 454D Composite Cover with Microgrip
part #132729

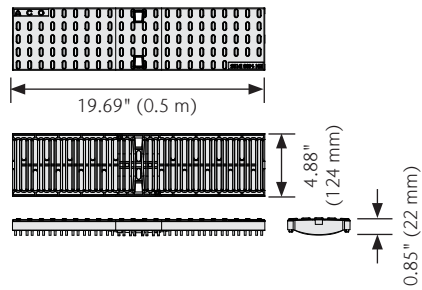

End Cap
part #96825

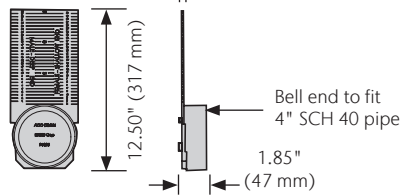

DK100 Polymer Concrete Duct

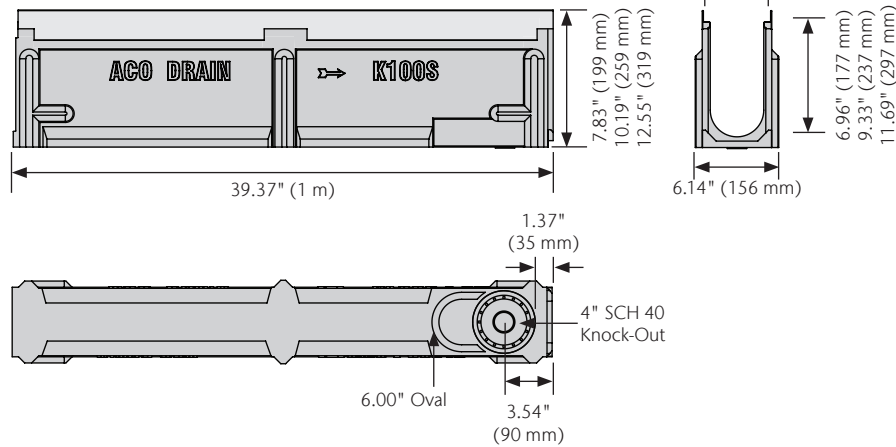

Specifications

General

The ducting system shall be ACO UtilityDuct DK100 complete with Type 454D Composite Cover with Microgrip secured with DrainLok as manufactured by ACO, Inc. or equal approved.

Materials

UtilityDuct system bodies are manufactured from polyester polymer concrete with minimum properties as follows:

- Compressive strength: 13,000 psi
- Flexural strength: 3,100 psi
- Water absorption: 0.07%
- Frost proof
- Salt proof
- Dilute acid and alkali resistant
- Surface burn characteristics of the material shall comply with UL 723

The nominal clear opening shall be 4" (100 mm) with overall width of 6.10" (155 mm). Modular units shall be manufactured with neutral invert and have a wall thickness of at least 0.50" (13 mm). Each unit will feature a full radius in the trench bottom and a male to female interconnecting end profile. Units shall have horizontal cast in anchoring features on the outside wall to ensure maximum mechanical bond to the surrounding bedding material and pavement surface. The galvanized steel edge rail will be integrally cast in by the manufacturer to ensure maximum homogeneity between polymer concrete body and edge rail. Each edge rail shall be at least 1/8" (3 mm) thick.

Grates

Type 454D Composite Covers with Microgrip Covers are manufactured from Polypropylene and Microgrip texture. Covers are held in place with DrainLok and load tested to meet EN 1433 Load Class B - 28,000 lbs - 581 psi.

Installation

The trench drain system shall be installed in accordance with the manufacturer's installation instructions and recommendations.

Parts

	Part #	Invert Depth in (mm)	Overall Depth in (mm)	Weight lbs
DK010 Polymer Concrete Duct - 39.37" (1 m)	99320	6.96 (177)	7.83 (199)	36.8
DK020 Polymer Concrete Duct - 39.37" (1 m)	99321	9.33 (237)	10.19 (259)	46.0
DK030 Polymer Concrete Duct - 39.37" (1 m)	99322	11.69 (297)	12.55 (319)	55.8
Type 454D Composite Cover with Microgrip (0.5 m)	132729	-	-	1.7
DK100 End Cap	96825	-	-	0.4

Notes:

1. DK100 duct is sold as channel only, cover is ordered as a separate item (two covers required per meter duct).
2. Preformed drill-out for 4" round or 6" oval to round pipe on underside of channel.

ACO, Inc.

West Sales Office
825 W. Beechcraft Street
Casa Grande, AZ 85122
Tel: (520) 421-9988
Toll-Free: (888) 490-9552
Fax: (520) 421-9899

Northeast Sales Office
9470 Pinecone Drive
Mentor, OH 44060
Tel: (440) 639-7230
Toll-Free: (800) 543-4764
Fax: (440) 639-7235

Southeast Sales Office
4211 Pleasant Road
Fort Mill, SC 29708
Toll-Free: (800) 543-4764
Fax: (803) 802-1063

info@acousa.com
www.acousa.com

© October 2020 ACO, Inc.

All reasonable care has been taken in compiling the information in this document. All recommendations and suggestions on the use of ACO products are made without guarantee since the conditions of use are beyond the control of the company. It is the customer's responsibility to ensure that each product is fit for its intended purpose and that the actual conditions of use are suitable. ACO, Inc. reserves the right to change products and specifications without notice.

ACO. creating
the future of drainage

