



Slab Solutions
Trench drains for concrete slabs

SlabDrain	100
MembraneDrain	108
FlowDrain	112

Slab Solutions features

Bolted grates - FG200 grates are lockable with two ½" - 13 x 1½" bolts fixing directly into steel frame at 18" (457mm) intervals.

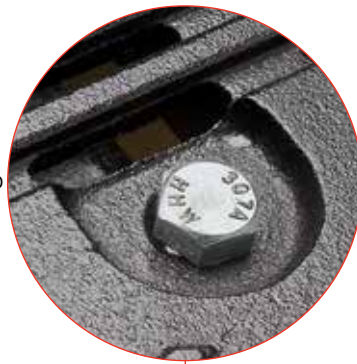

Fiberglass - A lightweight material that is made from polyester resin binder reinforced by glass matting and fibers.

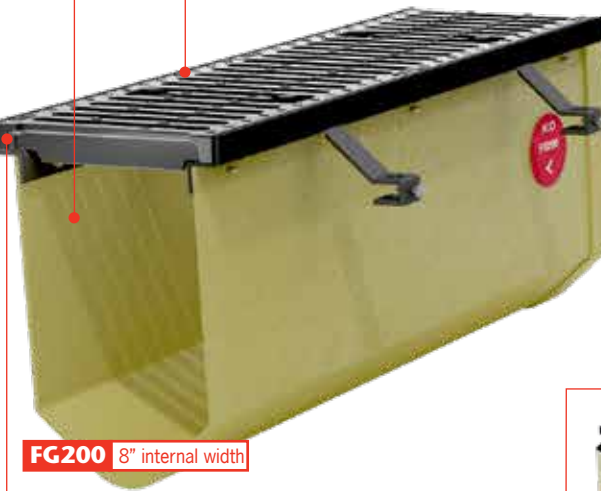

Choice of steel frame - Provides grate support and protects channel edge from damage. Available in black coated, galvanized and stainless steel.



Anti-shunt lugs - Recesses in grate fit around lugs on the edge rail to prevent longitudinal movement.



Interconnecting end profiles - Allow easy and effective joining of channels.
SF Sealant Groove - A groove is cast into the ends of every channel. The combined groove this creates allows for a positive bead of appropriate flexible sealant to be inserted at joints.



Ductile iron grates - Heavy duty ductile iron grates in choice of Load Class F slotted or longitudinal ADA compliant (H200SK & H300SK ADA grates are rated to Load Class E). A 4-bolt slotted grate is also available.

H100SK/H200SK/H300SK Integrally cast-in ductile iron edge rail - Provides maximum strength and protection for channel body.



Cross Sidewalk Drain - Allows water from a down spout to drain safely, through the SlabDrain, across the sidewalk to the curb.

H100K/H200K/H300K Integrally cast-in galvanized steel edge rail - Provides additional strength and protects channel body from damage. (Stainless steel edge rail also available).

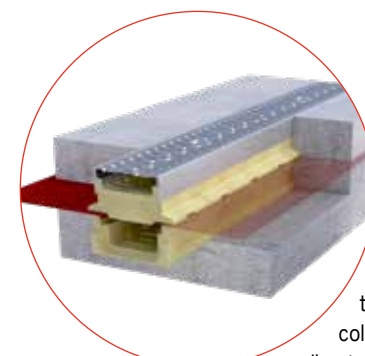

MembraneDrain - For use in a suspended slab where liquid permeating through the pavement is collected on a membrane and directed into the trench drain.



Wide choice of grates - In various materials, styles and slot configurations (including ADA compliant).
H100 - From Load Class A to Load Class C (25 tons).
H100K/H200K/H300K - From Load Class A to Load Class E (60 tons).

H100 Polymer concrete edge - Ideal for situations where metals cannot be used. Product is also used for the base of MembraneDrain.

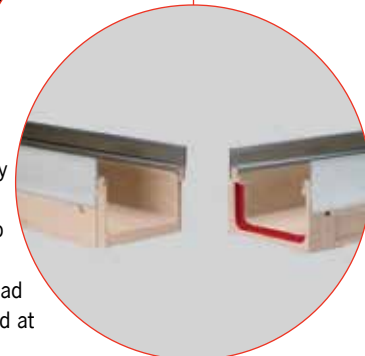
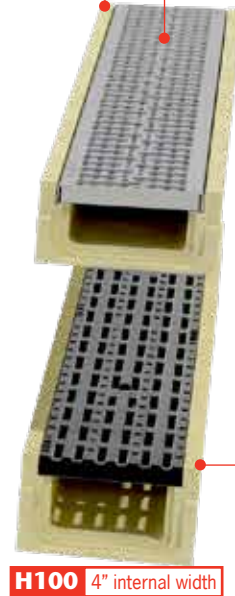

QuickLok™ & DrainLok™ on H100K/H200K/H300K - Patented, boltless locking systems provide quick fitting and removal of grates. Helps reduce installation/maintenance time and cost. H100 will accept QuickLok™ grates only.



Bottom drill-outs - Included on all channels to allow vertical evacuation of the system at any point in the run. Drill-outs sized for:
4" pipes - H100/H100K/H100SK,
4" & 6" pipes - H200K/H200SK,
6" & 8" pipes - H300K/H300SK





SlabDrain
Shallow invert trench drain

HK series	102
HSK series	104
H series	106

SlabDrain

Key dimensions

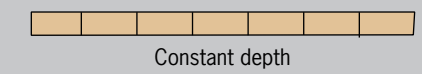
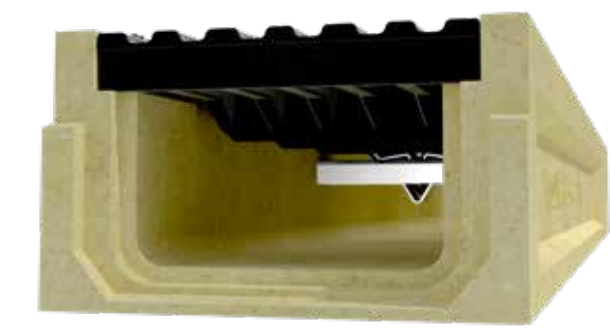
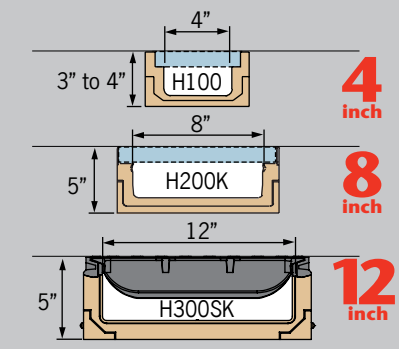

Typical applications

- Restricted depth applications
- Parking decks
- Elevated slabs
- Retro-fit
- Threshold applications

On occasion, installation constraints are of greater concern than hydraulics. The most common constraint is lack of depth. To offer solutions where shallow trench drains are required, SlabDrain is available in 3 edge versions and 3 widths - all constant depth.

Loading varies for each system, depending upon edge rail and grate, up to heavy duty Class F (90 tons) EN 1433. All grates are secured to the channel body by either QuickLok™ or PowerLok™.

Polymer concrete edge rail on H100-8/H100-10 can be used to provide a non-metallic drainage option.



Selection criteria

- Light to heavy industrial duty loads - dependent on type
- Product can be used towards LEED & EPA requirements
- Resistant to many everyday chemicals. *Check page 139*
- Multiple grate options to meet legal requirements
- Multiple grate options to meet design requirements
- Limited hydraulic capacity
- Constant depth channels

ACO DRAIN

System layout

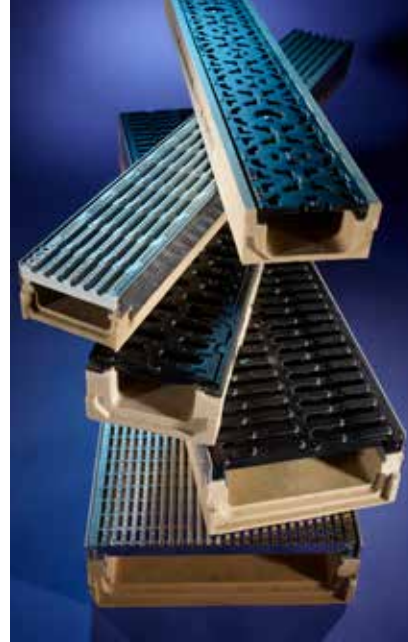
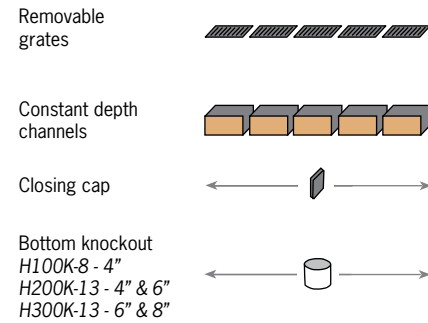

SlabDrain - H100K/H200K/H300K

H100KS/H200KS/H300KS

Outlet flow rates

Outlet Product	Size (Sch 40)	Invert in.	GPM	CFS
A Bottom outlet - H100K	4" round	2.56	87	0.20
A Bottom outlet - H200K	4" round	4.00	108	0.24
A Bottom outlet - H300K	6" round	4.00	243	0.54
B Bottom outlet - H200K	6" round	4.00	243	0.54
B Bottom outlet - H300K	8" round	4.00	432	0.96

Note: These are pipe flow rates at specified outlet, NOT channel flow rates.

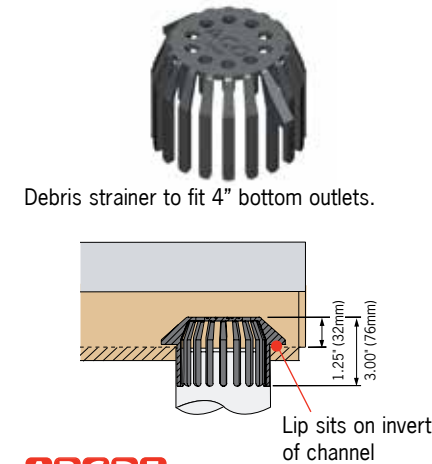

H100K-8/H100KS-8 channel

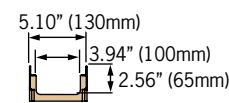
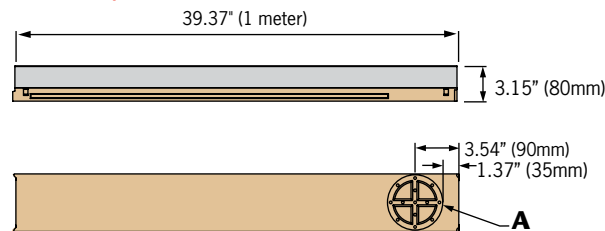

Closing cap

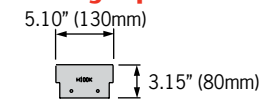

H100K-8/H100KS-8

Parts list

	Part No.		Invert Depth		Overall Depth		Volume	Weight
	H100K-8	H100KS-8	inches	mm	inches	mm	Gallons	lbs
Constant depth channel - 39.37" (1m)	95365	95373	2.56	65	3.15	80	1.2	16.0
Steel closing cap	98462	98471	-	-	3.15	80	-	1.0
Debris strainer for 4" bottom KO	93488	-	-	-	-	-	-	0.2
QuickLok™ locking bar	02899	-	-	-	-	-	-	0.1
Grate removal tool	01318	-	-	-	-	-	-	0.3

Notes:

- H100KS-8 has Grade 304 stainless steel rails and closing cap.
- See pages 30-33 for details on grates - for optimum flow use DrainLok™ grates.

H200K-13/H200KS-13 channel

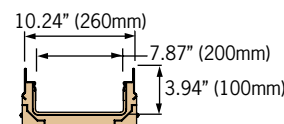
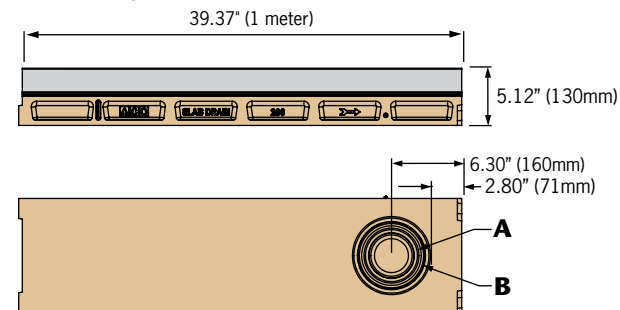

Closing cap

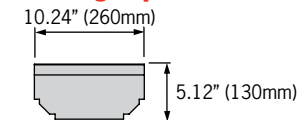

H200K-13/H200KS-13

Parts list

	Part No.		Invert Depth		Overall Depth		Volume	Weight
	H200K-13	H200KS-13	inches	mm	inches	mm	Gallons	lbs
Constant depth channel - 39.37" (1m)	93454	93455	3.94	100	5.12	130	3.7	57.4
Steel closing cap	93458	93459	-	-	5.12	130	-	1.0
Debris strainer for 4" bottom KO	93488	-	-	-	-	-	-	0.2
QuickLok™ locking bar	10457	-	-	-	-	-	-	0.5
Grate removal tool	01318	-	-	-	-	-	-	0.3

Notes:

- H200KS-13 has Grade 304 stainless steel rails and closing cap.
- See pages 42-43 for details on grates - for optimum flow use DrainLok™ grates.

H300K-13/H300KS-13 channel

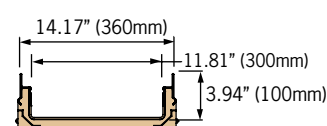
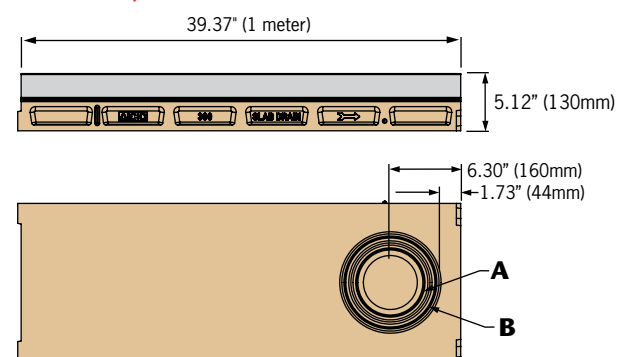

Closing cap

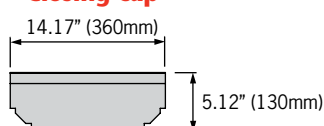

H300K-13/H300KS-13

Parts list

	Part No.		Invert Depth		Overall Depth		Volume	Weight
	H300K-13	H300KS-13	inches	mm	inches	mm	Gallons	lbs
Constant depth channel - 39.37" (1m)	93464	93465	3.94	100	5.12	130	5.5	71.6
Steel closing cap	93468	93469	-	-	5.12	130	-	1.4
QuickLok™ locking bar	10458	-	-	-	-	-	-	0.7
Grate removal tool	01318	-	-	-	-	-	-	0.3

Notes:

- H300KS-13 has Grade 304 stainless steel rails and closing cap.
- See pages 52-53 for details on grates - for optimum flow use DrainLok™ grates.

ACO DRAIN

System layout

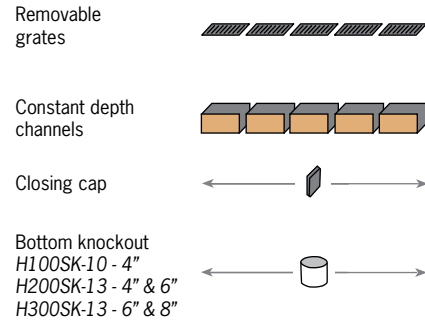

SlabDrain - H100SK/H200SK/H300SK

Outlet flow rates

Outlet Product	Size (Sch 40)	Invert in.	GPM	CFS
A Bottom outlet - H100SK	4" round	2.95	93	0.21
A Bottom outlet - H200SK	4" round	4.00	108	0.24
A Bottom outlet - H300SK	6" round	4.00	243	0.54
B Bottom outlet - H200SK	6" round	4.00	243	0.54
B Bottom outlet - H300SK	8" round	4.00	432	0.96

Note: These are pipe flow rates at specified outlet, NOT channel flow rates.



H100SK-10 channel

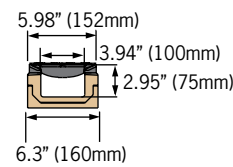
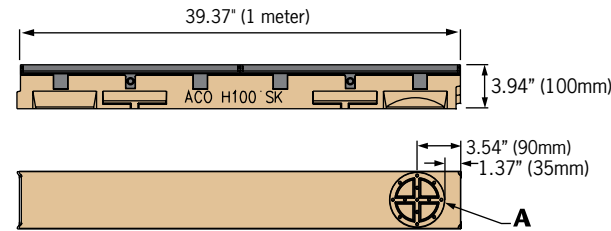

Closing cap

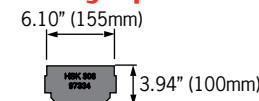

H100SK-10 Parts list

	Part No.	Invert Depth inches	mm	Overall Depth inches	mm	Volume Gallons	Weight lbs
Constant depth channel (no grate) - 39.37" (1m)	93412	2.83	72	3.15	80	1.2	43.5
Load Class F longitudinal grate - 19.69" (0.5m) PowerLok™	96096	-	-	-	-	-	13.6
Load Class F slotted grate - 19.69" (0.5m) PowerLok™	96082	-	-	-	-	-	12.3
Load Class F 4-bolt grate - 19.69" (0.5m)	99590	-	-	-	-	-	10.8
Replacement bolt	95526	-	-	-	-	-	0.1
Tamper resistant bolt for 4-bolt grate	138127	-	-	-	-	-	0.1
PowerLok™ safety clip	10443	-	-	-	-	-	0.1
Steel closing cap	93410	-	-	3.15	80	-	1.0
Debris strainer for 4" bottom knockout	93488	-	-	-	-	-	0.2
Grate removal tool	01318	-	-	-	-	-	0.3

Notes:

- See page 74 for details on grates.
- Debris strainer details for 4" dia. outlet on page 103.

H200SK-13 channel

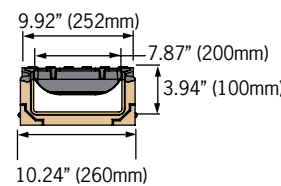
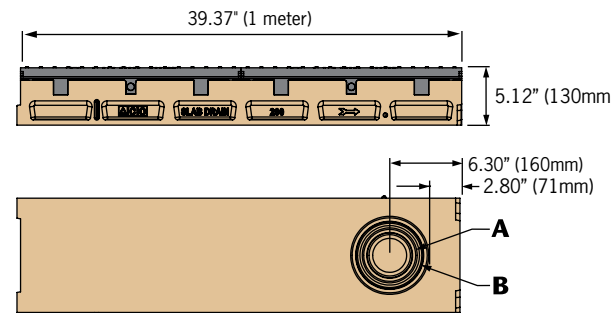

Closing cap

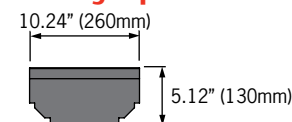

H200SK-13 Parts list

	Part No.	Invert Depth inches	mm	Overall Depth inches	mm	Volume Gallons	Weight lbs
Constant depth channel (no grate) - 39.37" (1m)	63456	3.94	100	5.12	130	3.7	66.4
Load Class E longitudinal grate - 19.69" (0.5m) PowerLok™	72263	-	-	-	-	-	26.4
Load Class F slotted grate - 19.69" (0.5m) PowerLok™	02449	-	-	-	-	-	30.8
Load Class F 4-bolt grate - 19.69" (0.5m)	99591	-	-	-	-	-	26.4
Replacement bolt	95526	-	-	-	-	-	0.1
Tamper resistant bolt for 4-bolt grate	138127	-	-	-	-	-	0.1
PowerLok™ safety clip	10443	-	-	-	-	-	0.1
Steel closing cap	93460	-	-	5.12	130	-	1.0
Debris strainer for 4" bottom knockout	93488	-	-	-	-	-	0.2
Grate removal tool	01318	-	-	-	-	-	0.3

Notes:

- See page 84 for details on grates.
- Debris strainer details for 4" dia. outlet on page 103.

H300SK-13 channel

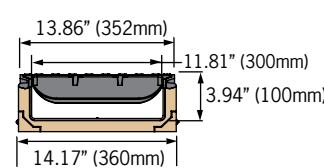
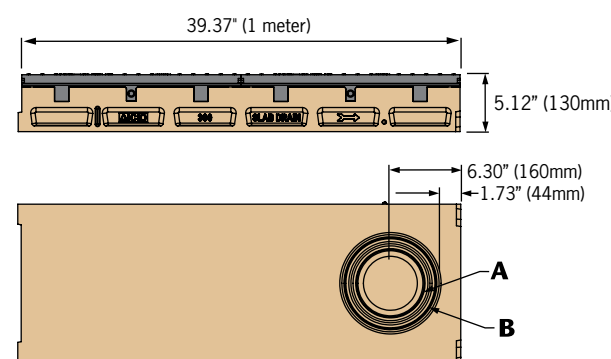

Closing cap

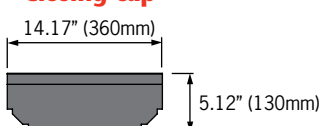

H300SK-13 Parts list

	Part No.	Invert Depth inches	mm	Overall Depth inches	mm	Volume Gallons	Weight lbs
Constant depth channel (no grate) - 39.37" (1m)	63466	3.94	100	5.12	130	5.5	82.2
Load Class E longitudinal grate - 19.69" (0.5m) PowerLok™	96833	-	-	-	-	-	64.0
Load Class F slotted grate - 19.69" (0.5m) PowerLok™	02445	-	-	-	-	-	50.0
Load Class F 4-bolt grate - 19.69" (0.5m)	99592	-	-	-	-	-	50.2
Replacement bolt	95526	-	-	-	-	-	0.1
Tamper resistant bolt for 4-bolt grate	138127	-	-	-	-	-	0.1
PowerLok™ safety clip	10443	-	-	-	-	-	0.1
Steel closing cap	93470	-	-	5.12	130	-	1.4
Grate removal tool	01318	-	-	-	-	-	0.3

Notes:

- See page 94 for details on grates.

ACO DRAIN

System layout

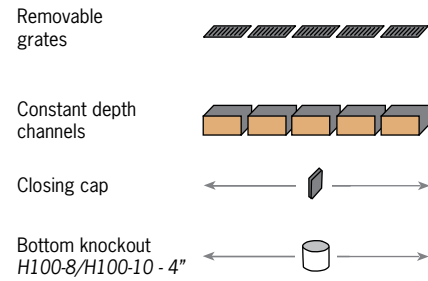

H100-8/10 channel

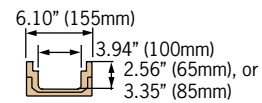
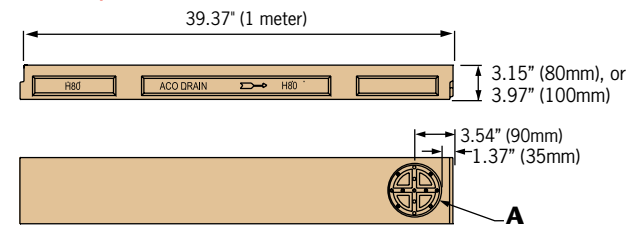

Closing cap

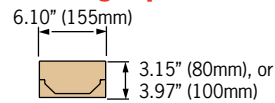

H100-8 & H100-10 Parts list

	Part No.	Invert Depth		Overall Depth		Volume Gallons	Weight lbs
		inches	mm	inches	mm		
H100-8 constant depth channel - 39.37" (1m)	00985	2.56	65	3.15	80	1.16	20.0
H100-10 constant depth channel - 39.37" (1m)	00549	3.35	85	3.95	100	1.70	25.0
H100-8 polymer concrete closing cap	05935	-	-	3.15	80	-	1.0
H100-10 polymer concrete closing cap	05939	-	-	3.95	100	-	1.0
Debris strainer for 4" bottom KO	93488	-	-	-	-	-	0.2
Grate removal tool	01318	-	-	-	-	-	0.3

Notes:

- See page 32 for details on suitable QuickLok™ grates, max. load Class C (56,000lb - 280psi).
 - Use grate removal tool to remove grates (Part #01318).
 - Debris strainer details for 4" dia. outlet on page 103.
- Use with 494Q (97393) or 495Q (97385) grates for non-metallic, non-locking drainage option - see ACO Sport brochure.

Outlet flow rates

Outlet Product	Size (Sch 40)	Invert in.	GPM	CFS
A Bottom outlet - H100-8	4" round	2.56	87	0.20
A Bottom outlet - H100-10	4" round	3.35	99	0.23

Note: These are pipe flow rates at specified outlet, NOT channel flow rates.

SlabDrain - H100/CSD

Cross Sidewalk Drain (CSD)

CSD is a cross sidewalk drainage system which has a polymer concrete curb unit, that is cast into the curb line, to allow water from the H100K-8 or H100KS-8 SlabDrain to discharge into the road. A down spout inlet, also manufactured from polymer concrete, allows rainwater down spouts to drain into the channel.

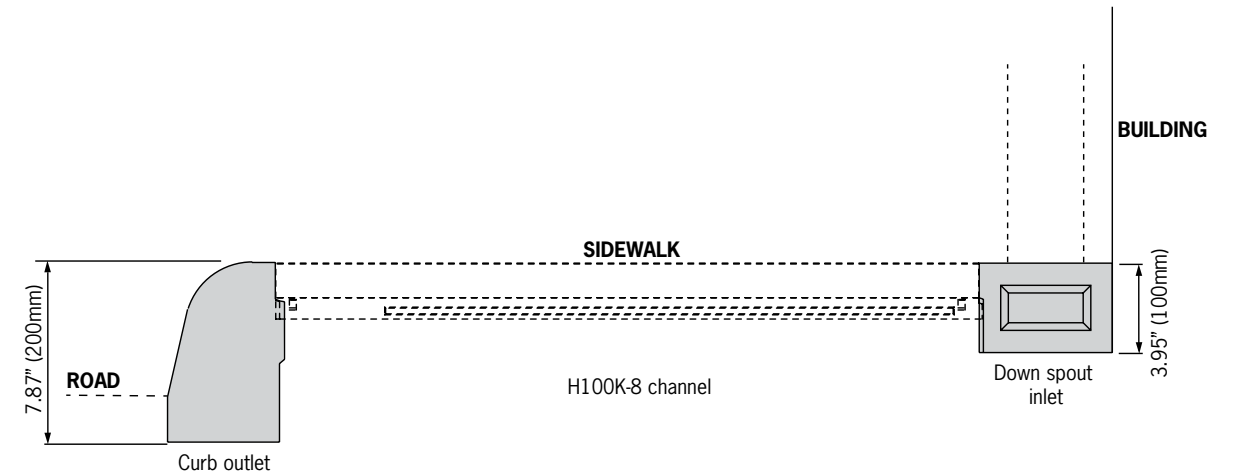

CSD Parts list

	Part No.	Invert Depth		Overall Depth		Weight lbs
		inches	mm	inches	mm	
Curb outlet - type 6 profile	96924	3.5	90	7.87	200	12.7
Down spout inlet	96932	3.2	82	3.95	100	6.0

Notes:

- For use with H100K-8 or H100KS-8 channels only - see page 102-103 for details.





MembraneDrain - External elevated slab drain

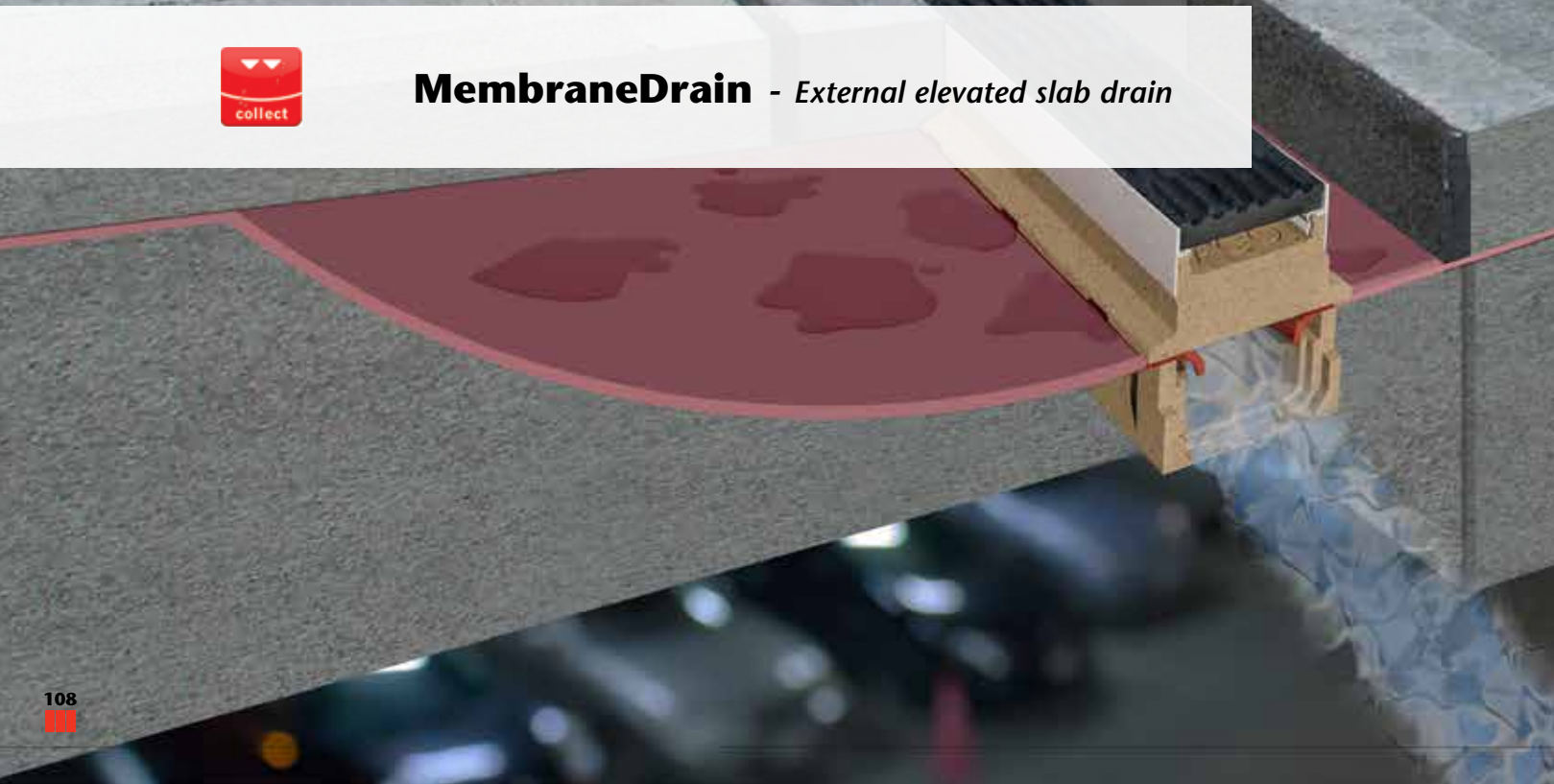

MembraneDrain

Key dimensions

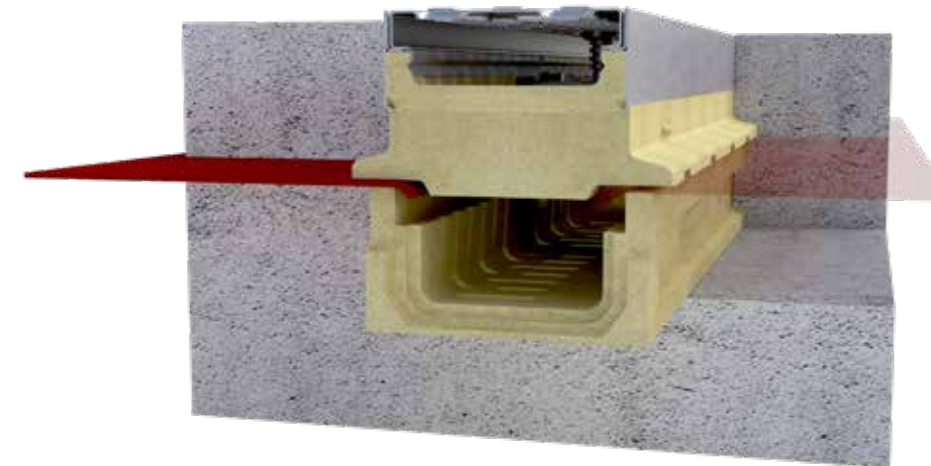
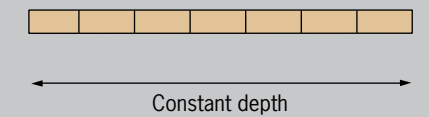
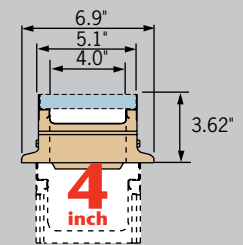

Specifically for use in suspended slab where any liquid permeating through the pavement is collected and directed into the trench drain.

Loading is determined by grate, up to Load Class C (25 ton).

For membrane applications above a habitable area, ACO Building Drainage offers ProfilLine and other suitable products manufactured from stainless steel that are installed entirely above the membrane.

Typical applications

- Rail stations
- Parking garages
- Office buildings
- Airports
- Roof top gardens

Selection criteria



Light to medium duty loads



Product can be used towards LEED & EPA requirements



Resistant to many everyday chemicals. *Check page 139*



Multiple grate options to meet legal requirements



Multiple grate options to meet design requirements



Limited hydraulic capacity



Constant depth channels



MembraneDrain features

Clamping device - An inverted 'U' shaped locking bar is fitted to the H100-8/H100-10 channel. The locking bar is fitted to the MembraneDrain subframe. Two bolts allow connection between the two bars and hold the membrane tight.

Grates - Sit directly into the MembraneDrain subframe and lock into position with DrainLok™ or QuickLok™.

Membrane - Is clamped between channel and subframe. Maximum membrane of 1/2" (12.7mm) can be accommodated - ensure weep holes are not blocked if using a thick or hot-mopped membrane. Liquids seep through the pavement, collect on the membrane (not supplied by ACO) and drain into channel.

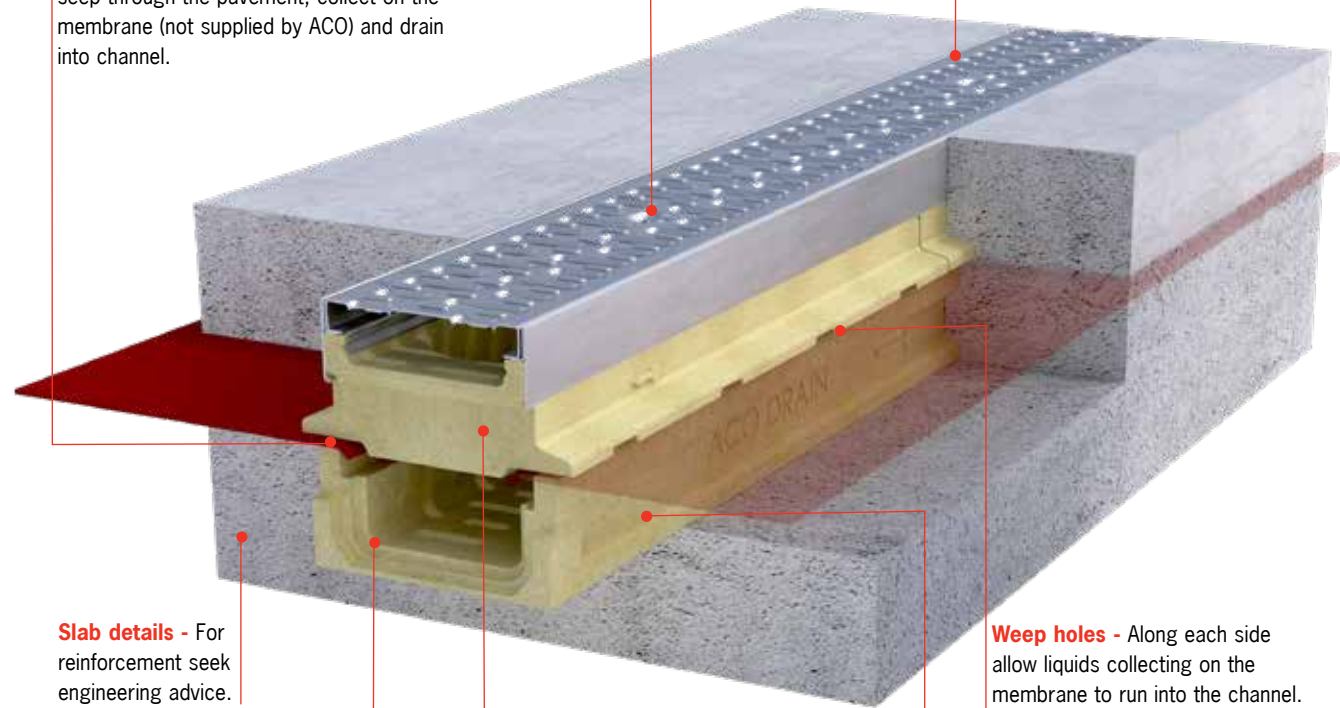

Slab details - For reinforcement seek engineering advice.

Weep holes - Along each side allow liquids collecting on the membrane to run into the channel. Each weep hole opening is 1.18" (30mm) x 0.15" (4mm).

Membrane end cap - Cut down and use top part of K100 closing cap to close end of subframe (Part #96822). See page 28 for details.

End caps and accessories - Are available from the H100-8/H100-10 range. See page 106 for details.

Used with H100-8/H100-10 channel - MembraneDrain subframe fits directly on the H100-8/H100-10 channels. See page 106 for details.

MembraneDrain Parts list

Description	Part No.		Invert Depth		Overall Depth		Weight
	Galv.	Stainless	inches	mm	inches	mm	lbs
MembraneDrain subframe - 19.69" (0.5m)	96903	96918	-	-	3.62	92	9.7
MembraneDrain clamping device	96905	96913	-	-	-	-	0.9

Notes:

1. For H100-8/H100-10 channel information see page 106.

Half meter subframe

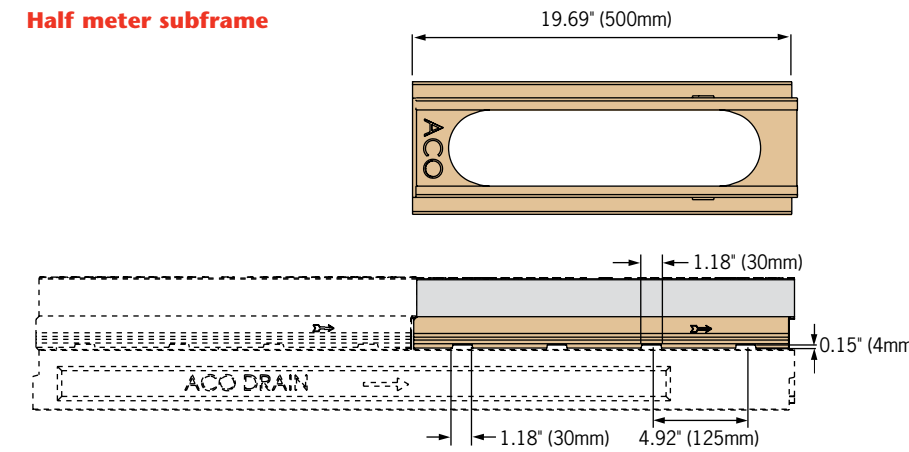

End view

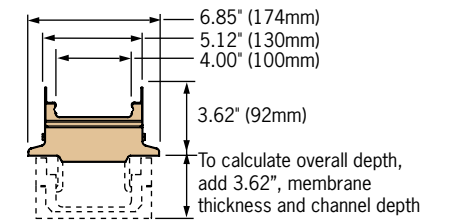

Clamping device



Membrane collects liquids that seep through surface materials.

Two assembly screws

Locking bar with QuickLok™ locking mechanism

Inverted U locking bar fits in channel and locks subframe unit and channel together



Section through MembraneDrain system

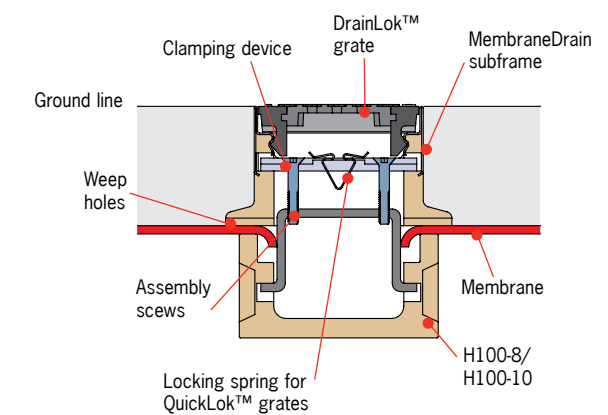



FlowDrain - FG200

Key dimensions

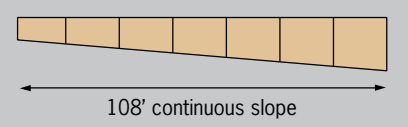
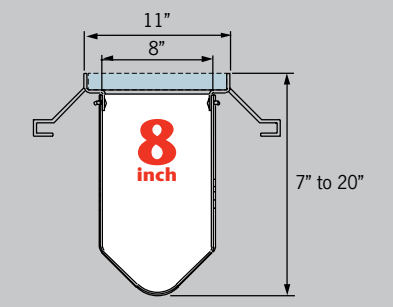







FG200 is an 8" wide fiberglass system with choice of steel slotted Class C (25 ton) or ductile iron Class E (60 ton) grates. Grates are bolted into the steel frame with 2 bolts per 18" section.

Typical applications

- Parking lots & garages
- Airports
- Gas stations
- Industrial areas
- Commercial areas
- Internal applications

Selection criteria

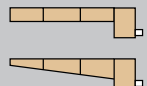
- A B C D E** Light to heavy industrial duty loads 
-  Product can be used towards LEED & EPA requirements
-  Resistant to many everyday chemicals. *Check page 139*
-  Multiple grate options to meet legal requirements
-  Multiple grate options to meet design requirements
-  Increased hydraulic capacity
-  Constant depth and/or sloped depth channels



FlowDrain FG200 - 8" wide fiberglass system



FlowDrain features

Bolted grates - FG200 grates are lockable with two ½" - 13 x 1½" bolts fixing directly into steel frame at 18" (457mm) intervals.

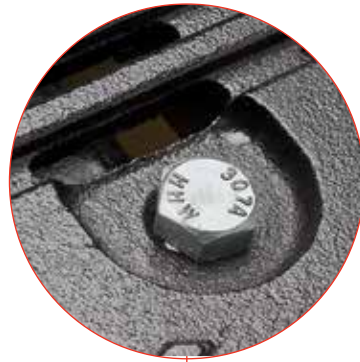

Choice of grates - In various materials and styles (including ADA compliant) for applications up to Load Class E.

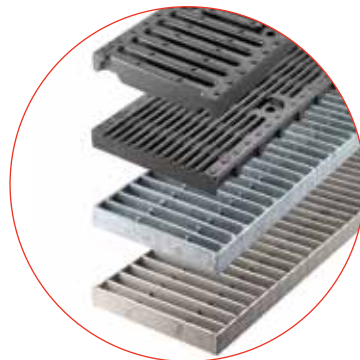

Interconnecting end profiles - Allow easy and effective joining of channels. Sealant can be used to create sealed joints.

Bracing blocks - Supplied to brace deeper channels during concrete pour, details on how to position are shown on a sticker on each channel.

FG200 18" internal width

Nelson studs - Attached to frame, act as concrete anchors to secure channels into concrete surround.

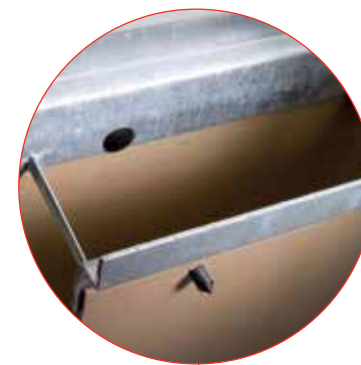

Snap-fit studs - Hold channel body securely to frame and allows quick assembly on-site. Supplied with frame.

Direction arrows - Sticker on side of channel indicates flow direction and ensures channels are installed correctly.

Sloped (1.0%) channel units - 9' (2.75 meter) long units provide 108' (32.9 meter) continuous slope. Equates to 1/8" fall per linear foot. Four constant depth channels extend run lengths. Four 3' (0.915 meter) units and accessories also available.



Installation brackets - Provide simple and easy installation using No. 4 or 5 rebar.



Choice of steel frame - Provides grate support and protects channel edge from damage. Available in black coated, galvanized and stainless steel.

Fiberglass - A lightweight material that is made from polyester resin binder reinforced by glass matting and fibers. See page 136 for material properties.

System layout

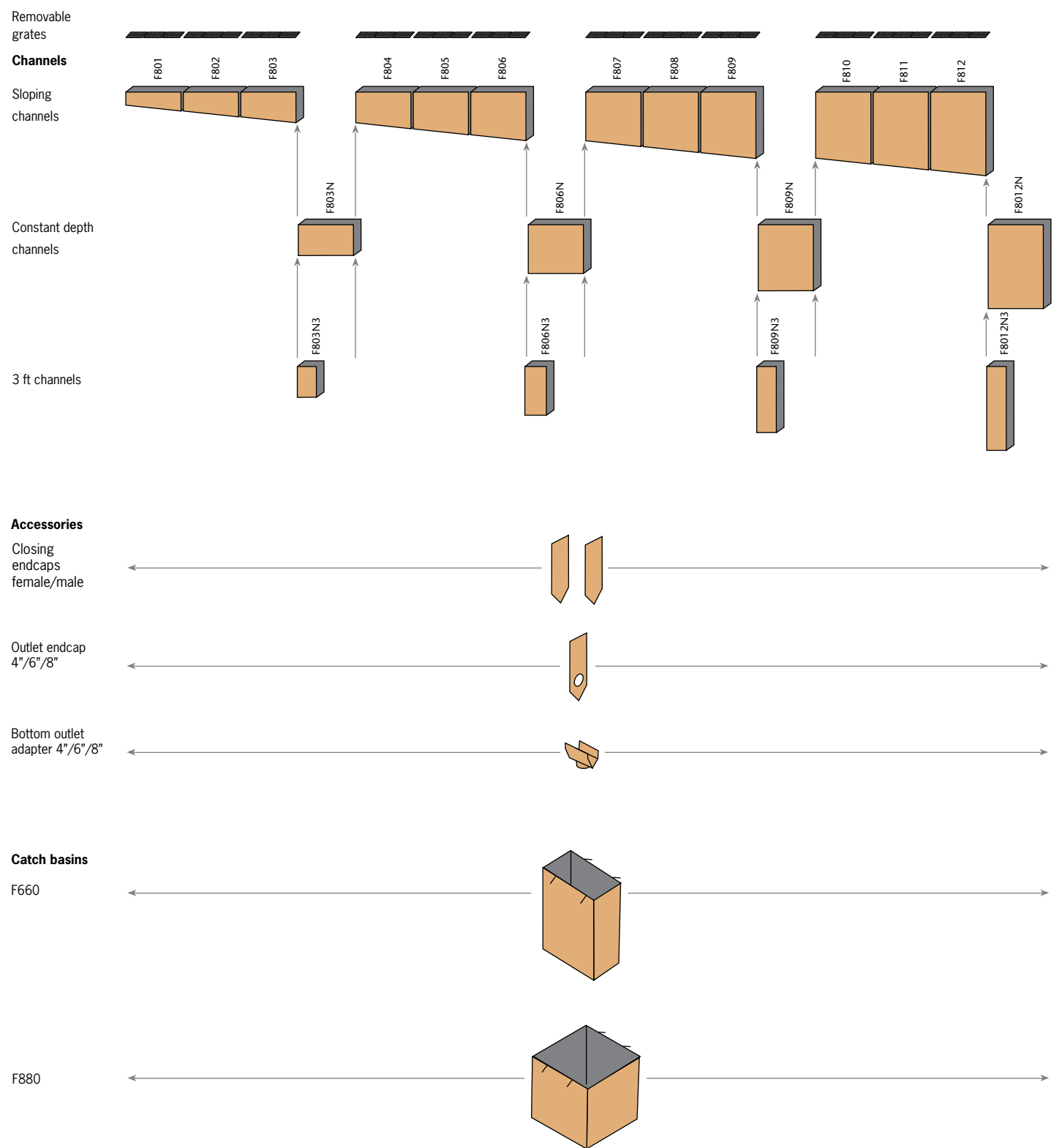

9 ft channel

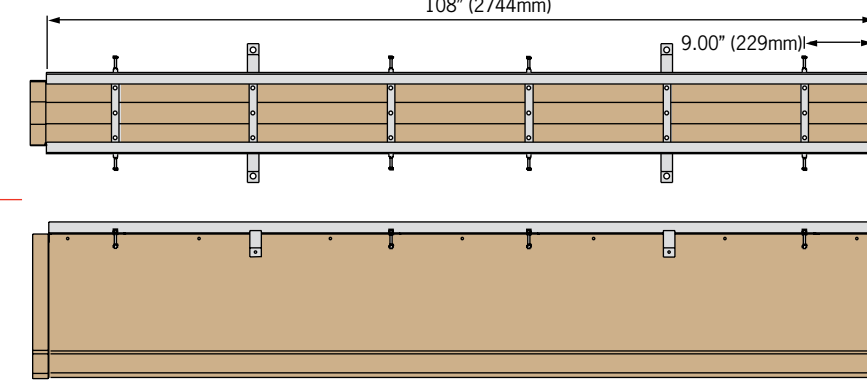

3 ft channel

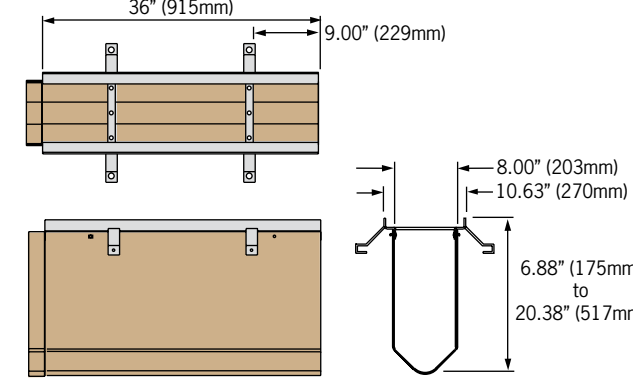

Outlet flow rates

Channels				
Outlet	Size (Sch 40)	Invert in.	GPM	CFS
A	4" round	7.88	154	0.34
A	4" round	20.25	246	0.54
B	6" round	7.88	346	0.77
B	6" round	20.25	553	1.23
C	8" round	7.88	616	1.37
C	8" round	20.25	982	2.18
D	4" round	9.00	145	0.33
D	4" round	20.25	233	0.54
E	6" round	10.13	330	0.76
E	6" round	20.25	510	1.17
F	8" round	12.38	635	1.46
F	8" round	20.25	880	2.03

Catch basins		F660			F880		
Outlet	Size (Sch 40)	Invert in.	GPM	CFS	Invert in.	GPM	CFS
G	4" round	26.50	269	0.60	27.50	275	0.61
H	6" round	26.50	594	1.32	27.50	606	1.35
I	8" round	26.50	1032	2.30	27.50	1055	2.35

Note: These are pipe flow rates at specified outlet, NOT channel flow rates. Catch Basin flow rates without trash bucket - using trash bucket reduces flow.

Closing cap (Female)

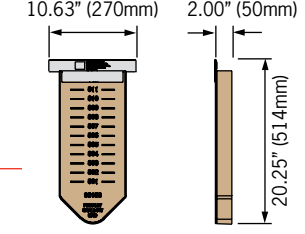

Closing cap (Male)

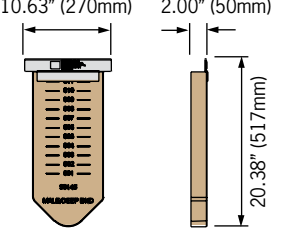

Outlet end cap

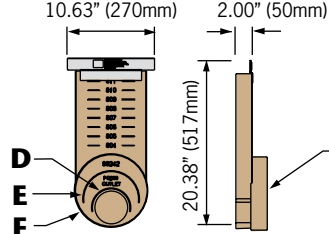

Vertical outlet adapter

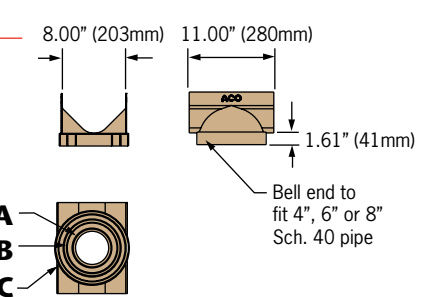

FF660 Catch Basin

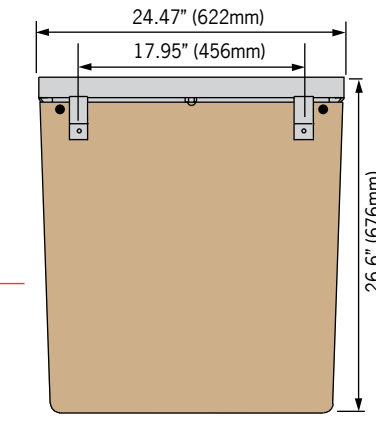

FF880 Catch Basin

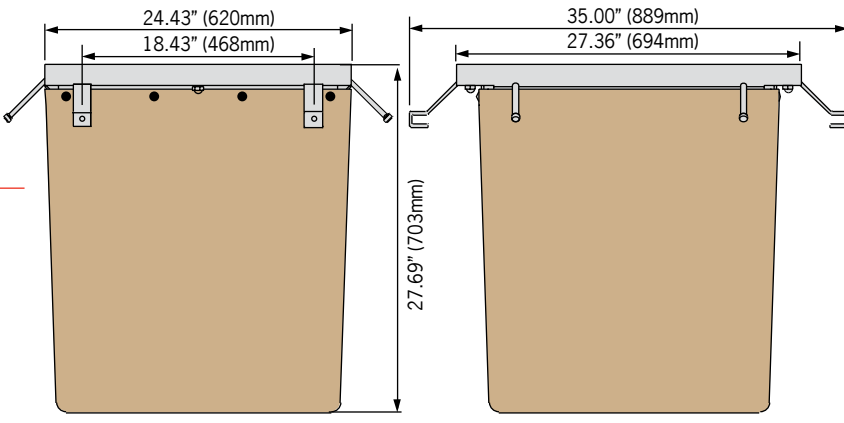

Pipe adapter

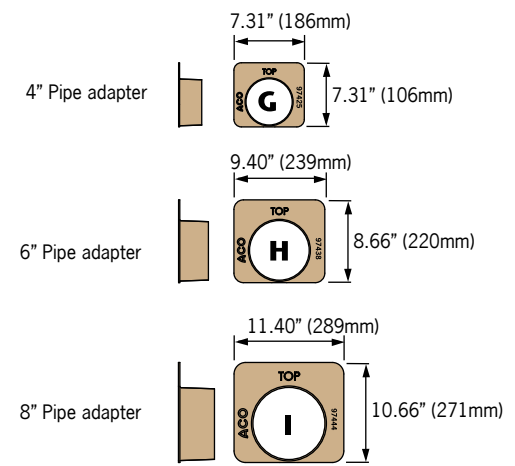

Channel collar

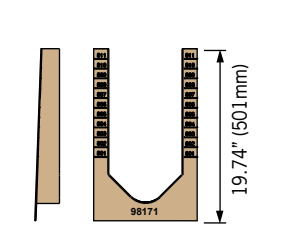

FlowDrain - FG200

9 ft channels

1.0% sloped channels in 9' lengths and 12 depths which connect to create 108' (32.9 meters) continuously sloping trench run. Constant depth channels are available in 4 depths and can be used to create non-sloped runs or inserted in sloped runs to increase length. Choice of 9' black coated, stainless or galvanized steel frame connects to channel body using simple snap-fit studs.

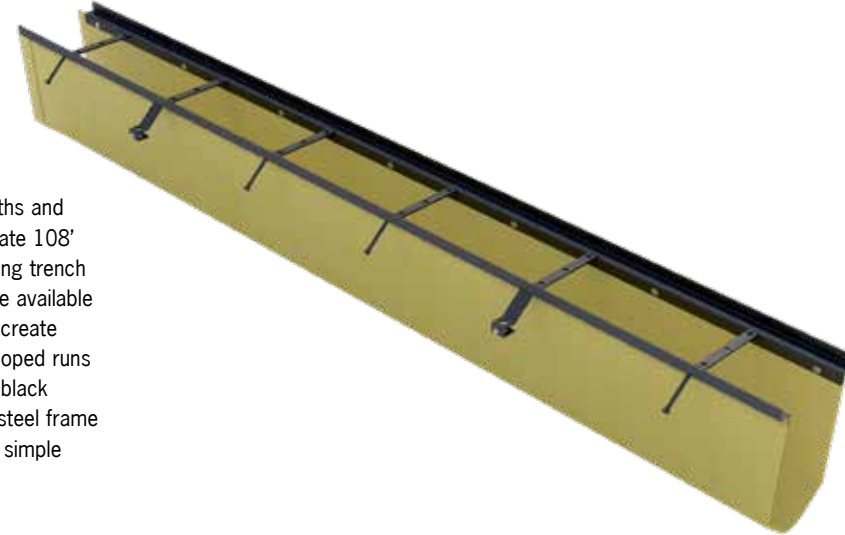

3 ft channels

Constant depth channels in 4 depths to supplement the 9' channels for easier layouts. Choice of 3' black coated, stainless or galvanized steel frame connects to channel body using simple snap-fit studs.



Male closing cap

Fits outside deep/male end of all channels. Manufactured from polypropylene with choice of black coated, stainless or galvanized steel end rail. Guides aid cutting to correct height. Seal using appropriate flexible sealant.



Female closing cap

Fits inside shallow/female end of channel. Manufactured from polypropylene with choice of black coated, stainless or galvanized steel end frame. Guides aid cutting to correct height. Seal using appropriate flexible sealant.



Outlet cap

Fits outside deep/male end of all channels. Manufactured from polypropylene with choice of black coated, stainless or galvanized steel end rail. Guides aid cutting to correct height. Seal using appropriate flexible sealant. Bell end connection to fit 4", 6" or 8" Schedule 40 pipes.



Note: For depth 801-804 channels ACO recommends removal of unused sections of the bell end to ensure adequate pavement material coverage.

Vertical outlet adapter

4", 6" or 8" Schedule 40 vertical outlet adapter manufactured from polypropylene. Can be secured to underside of channel using appropriate flexible sealant to provide vertical bell end for easy attachment to 4", 6" or 8" Schedule 40 pipe. Can be used anywhere along channel.



F660 & F880 catch basins

One piece fiberglass catch basins with choice of black coated, stainless or galvanized steel frame, lockable steel bar or ductile iron slotted grate and plastic trash bucket.

Accessories include 4", 6" and 8" Schedule 40 pipe adapters and channel collars to connect channel to catch basin.

See page 121 for details.



ACO DRAIN

FG200 Parts table

	Part No.	Invert Depth				Overall Depth				Vol Gal	Wgt lbs
		Inches		mm		Inches		mm			
		female	male	female	male	female	male	female	male		
F801 Sloped channel - 108" (2.75m)	99006	6.75	7.88	172	200	6.88	8.01	175	203	18.37	11.0
F802 Sloped channel - 108" (2.75m)	99013	7.88	9.00	200	229	8.01	9.13	203	232	22.58	12.0
F803 Sloped channel - 108" (2.75m)	99021	9.00	10.13	229	257	9.13	10.26	232	260	26.79	13.0
F803N Constant depth channel - 108" (2.75m)	99048	10.13	10.13	257	257	10.26	10.26	260	260	28.80	15.5
F803N3 Constant depth channel - 36" (0.915m)	99034	10.13	10.13	257	257	10.26	10.26	260	260	9.60	5.2
F804 Sloped channel - 108" (2.75m)	99055	10.13	11.25	257	286	10.26	11.38	260	289	31.00	14.1
F805 Sloped channel - 108" (2.75m)	99062	11.25	12.38	286	314	11.38	12.51	289	318	35.21	15.2
F806 Sloped channel - 108" (2.75m)	99071	12.38	13.50	314	343	12.51	13.63	318	346	39.42	16.3
F806N Constant depth channel - 108" (2.75m)	99095	13.50	13.50	343	343	13.63	13.63	346	346	41.50	16.3
F806N3 Constant depth channel - 36" (0.915m)	99084	13.50	13.50	343	343	13.63	13.63	346	346	13.83	5.5
F807 Sloped channel - 108" (2.75m)	99109	13.50	14.63	343	371	12.63	14.76	346	375	43.63	17.4
F808 Sloped channel - 108" (2.75m)	99116	14.63	15.75	371	400	14.76	15.88	375	403	47.84	18.5
F809 Sloped channel - 108" (2.75m)	99123	15.75	16.87	400	429	15.88	17.00	403	432	52.05	19.6
F809N Constant depth channel - 108" (2.75m)	99145	16.87	16.87	429	429	17.00	17.00	432	432	54.10	19.6
F809N3 Constant depth channel - 36" (0.915m)	99132	16.87	16.87	429	429	17.00	17.00	432	432	18.00	6.5
F810 Sloped channel - 108" (2.75m)	99156	16.87	18.00	429	457	17.00	18.13	432	460	56.26	20.7
F811 Sloped channel - 108" (2.75m)	99162	18.00	19.13	457	486	18.13	19.26	460	489	60.47	21.8
F812 Sloped channel - 108" (2.75m)	99175	19.13	20.25	486	514	19.26	20.38	489	518	64.68	23.0
F812N Constant depth channel - 108" (2.75m)	99192	20.25	20.25	514	514	20.38	20.38	518	518	66.76	23.0
F812N3 Constant depth channel - 36" (0.915m)	99186	20.25	20.25	514	514	20.38	20.38	518	518	22.25	7.7
Black coated steel frame - 108" (2.75m)	97066	-	-	-	-	-	-	-	-	-	57.9
Black coated steel frame - 36" (0.915m)	98524	-	-	-	-	-	-	-	-	-	19.3
Galvanized steel frame - 108" (2.75m)	97079	-	-	-	-	-	-	-	-	-	57.9
Galvanized steel frame - 36" (0.915m)	98538	-	-	-	-	-	-	-	-	-	19.3
Stainless steel frame - 108" (2.75m)*	97087	-	-	-	-	-	-	-	-	-	57.9
Stainless steel frame - 36" (0.915m)*	98545	-	-	-	-	-	-	-	-	-	19.3
Closing cap (female) with black end frame	98365	-	-	-	-	20.38	20.38	518	518	-	1.1
Closing cap (female) with galv. steel end frame	98386	-	-	-	-	20.38	20.38	518	518	-	1.1
Closing cap (female) with S/S end frame	98375	-	-	-	-	20.38	20.38	518	518	-	1.1
Closing cap (male) with black end frame	98363	-	-	-	-	20.38	20.38	518	518	-	1.3
Closing cap (male) with galv. steel end frame	98382	-	-	-	-	20.38	20.38	518	518	-	1.3
Closing cap (male) with S/S end frame	98372	-	-	-	-	20.38	20.38	518	518	-	1.3
Outlet cap (male) with black end frame	98361	20.25	20.25	514	514	20.38	20.38	518	518	-	1.8
Outlet cap (male) with galv. steel end frame	98381	20.25	20.25	514	514	20.38	20.38	518	518	-	1.8
Outlet cap (male) with S/S end frame	98373	20.25	20.25	514	514	20.38	20.38	518	518	-	1.8
Vertical outlet adapter - 4", 6" or 8" outlet	98103	20.25	20.25	514	514	20.38	20.38	518	518	-	1.6

Notes:

- Invert depths are for the channel body & frame assembled.
- Channel weights are for fiberglass body only.
- Closing/Outlet caps can be cut down to suit all channels.
- Add 2" to length of each channel for female joining flange (only applicable at shallowest end of trench run).
- Frames supplied with plastic snap-fit studs for connecting to fiberglass body.
- See page 122 for grate details.
- Grade 304 stainless steel frames, ACO recommends the use of non-galvanized grates with stainless steel frames to avoid galvanic corrosion.

FlowDrain - FG200

Fiberglass catch basins

Fiberglass catch basins are available with a variety of frames and grates. Channel collars are available to connect all depths of channel on any side of the catch basin. Pipe adapters are available to allow inlet/outlet pipe connections at any position on the catch basin.

F660 catch basin

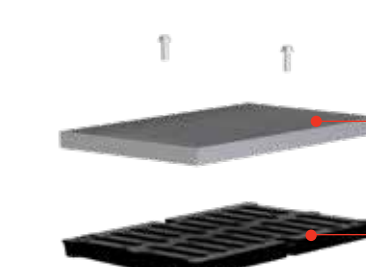

Grates - a choice of galvanized or stainless steel bar or slotted ductile iron grates, locked in place with 2 bolts. See page 123.

Trash bucket - plastic trash bucket designed to collect debris that has collected in the trench and washed into the catch basin.

Frame - coated black, galvanized or stainless steel frame attached to catch basin body with snap-fit studs.

Catch basin body - fiberglass body in choice of 2 sizes.

Channel collar - adapter to enable smooth transition of any depth FG200 channel on any side. Can be cut to correct height.

Pipe adapter - plain end adapter to allow inlet or outlet pipes to be easily attached to the outer wall of catch basin at any position. Available for 4", 6" and 8" Schedule 40 pipes.

F880 catch basin

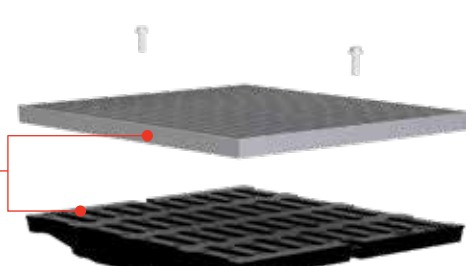

Parts table - FG200 Catch basins	Part No.	Volume Gallons	Weight lbs
F660 catch basin - 24" x 12"	98069	27.00	22.0
F660 black coated steel frame	97995	-	13.8
F660 galvanized steel frame	98008	-	14.4
F660 stainless steel frame*	98013	-	14.4
F660 plastic trash bucket	98067	-	5.0
F880 catch basin - 24" x 24"	98075	55.00	22.0
F880 black coated steel frame	98021	-	23.2
F880 galvanized steel frame	98034	-	24.2
F880 stainless steel frame*	98048	-	24.2
F880 plastic trash bucket	98059	-	8.4
FG200 channel/catch basin adapter	98171	-	1.1
4" pipe plain end adapter	97425	-	0.4
6" pipe plain end adapter	97438	-	0.6
8" pipe plain end adapter	97444	-	0.9

* Grade 304 stainless steel frames. ACO recommends use of non-galvanized grates with stainless steel frames to avoid galvanic corrosion.

Available FG200 grates

Description	Part No.	Length inches (m)	Slot Size inches	Intake area sq. in.	Wgt lbs	Locking mechanism	Compliant with Americans with Disabilities Act of 1990 Section 4.5.4 (Page 140)	ASME A112.6.3 - 2001 Heel resistant less than 0.31" (8mm) (Page 140)	Anti-slip grates - BPN over 24 (Page 140)	200,000lb proof load compliant (Page 128)	SAFE	Commercial vehicle
C Load Class C - 56,000lbs - EN 1433												968psi

Bar steel

Galvanized ¹	93899	36" (0.9m)	1.0 x 3.6	264.0	28.6	Bolt	X	X	X	✓		54.3
Stainless* ²	93891	36" (0.9m)										

* Grade 304 stainless steel.

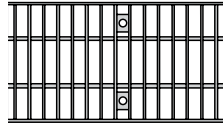

E Load Class E - 135,000lbs - EN1433												2,321psi	Industrial
---	--	--	--	--	--	--	--	--	--	--	--	----------	------------

Slotted iron

Iron ³	93896	18" (0.45m)	0.61 x 7.87	58.7	25.2	Bolt	X	X	X	X		29.0
-------------------	-------	-------------	-------------	------	------	------	---	---	---	---	--	------

Ductile iron to ASTM A 536-84 - minimum grade 64-45-12. This grate complies with RR-F-621E '200,000lb proof load' test.

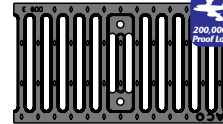

Longitudinal iron

Iron ³	93893	18" (0.45m)	1.75 x 0.25	35.0	28.2	Bolt	✓	✓	✓	✓		31.9
-------------------	-------	-------------	-------------	------	------	------	---	---	---	---	--	------

Ductile iron to ASTM A 536-84 - minimum grade 64-45-12. This grate complies with RR-F-621E '200,000lb proof load' test.

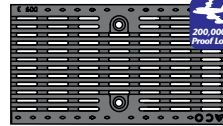

- Notes:
- Supplied with 4 galvanized steel socket head bolts (1/2" - 13 x 1 1/2") - replacement part 93895.
 - Supplied with 4 stainless steel socket head bolts (1/2" - 13 x 1 1/2") - replacement part 93897.
 - Supplied with 2 stainless steel hex head bolts (1/2" - 13 x 1 1/2") - replacement part 93892.

Key

- Locking mechanism
- Heel safe equal or less than 0.25" (6.5mm) (Page 140)
- 200,000lb proof load compliant (Page 128)
- Compliant with Americans with Disabilities Act of 1990 Section 4.5.4 (Page 140)
- Bicycle Safe compliant to Australian Standard AS 3996 - 2006 (Page 140)
- ASME A112.6.3 - 2001 Heel resistant less than 0.31" (8mm) (Page 140)
- Anti-slip grates - BPN over 24 (Page 140)

Bolted grates

Bolted FG200 grates offer mechanical, secure fixing of grates into the channel frame. Two bolts per 18" grate section lock into cross bars in the steel frame. Care must be taken to ensure that all bolts are secure and are not overtightened which can damage the frame.



- Fit grate**
Position grate onto channel, align holes in grate with matching holes in frame cross bar.
- Grate removal**
Using wrench or socket set to tighten. If using a torque wrench do not set to more than 15 ft. lbs.
- Grate removal**
To remove grates use wrench or socket set. Carefully store bolts for refitting of grates.

Available F660 grates

Description	Part No.	Length inches (m)	Slot Size inches	Intake area sq. in.	Wgt lbs	Locking mechanism	Compliant with Americans with Disabilities Act of 1990 Section 4.5.4 (Page 140)	ASME A112.6.3 - 2001 Heel resistant less than 0.31" (8mm) (Page 140)	Anti-slip grates - BPN over 24 (Page 140)	200,000lb proof load compliant (Page 128)	SAFE	Commercial vehicle
C Load Class C - 56,000lbs - EN 1433												739psi

Bar steel

Galvanized ¹	97443	24" (0.6m)	1.0 x 3.3	267.0	35.2	Bolt	X	X	X	✓		54.3
Stainless* ²	97442	24" (0.6m)										

* Grade 304 stainless steel.

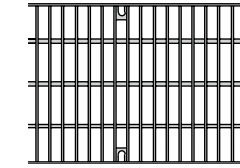

E Load Class E - 135,000lbs - EN1433												1,773psi	Industrial
---	--	--	--	--	--	--	--	--	--	--	--	----------	------------

Slotted iron

Iron ³	97449	24" (0.6m)	1.2 x 6.1 avg	130.0	75.0	Bolt	X	X	X	✓		31.0
-------------------	-------	------------	---------------	-------	------	------	---	---	---	---	--	------

Ductile iron to ASTM A 536-84 - minimum grade 64-45-12

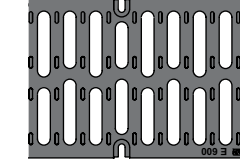

Available F880 grates

Description	Part No.	Length inches (m)	Slot Size inches	Intake area sq. in.	Wgt lbs	Locking mechanism	Compliant with Americans with Disabilities Act of 1990 Section 4.5.4 (Page 140)	ASME A112.6.3 - 2001 Heel resistant less than 0.31" (8mm) (Page 140)	Anti-slip grates - BPN over 24 (Page 140)	200,000lb proof load compliant (Page 128)	SAFE	Commercial vehicle
C Load Class C - 56,000lbs - EN 1433												739psi

Bar steel

Galvanized ¹	97452	24" (0.6m)	1.0 x 3.3	456.0	63.8	Bolt	X	X	X	✓		54.3
Stainless* ²	97455	24" (0.6m)										

* Grade 304 stainless steel.

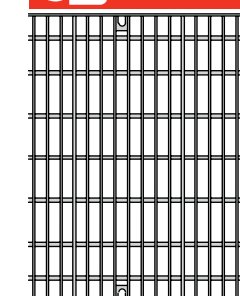

E Load Class E - 135,000lbs - EN1433												1,773psi	Industrial
---	--	--	--	--	--	--	--	--	--	--	--	----------	------------

Slotted iron

Iron ³	97453	24" (0.6m)	1.2 x 5.5	226.0	206.0	Bolt	X	X	X	✓		23.8
-------------------	-------	------------	-----------	-------	-------	------	---	---	---	---	--	------

Ductile iron to ASTM A 536-84 - minimum grade 64-45-12

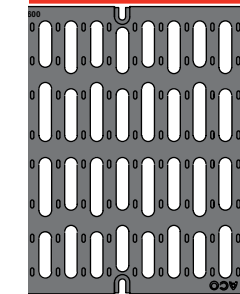

- Notes:
- Supplied with 2 galvanized steel socket head bolts (1/2" - 13 x 1 1/2") - replacement part 93895.
 - Supplied with 2 stainless steel socket head bolts (1/2" - 13 x 1 1/2") - replacement part 93897.
 - Supplied with 2 stainless steel hex head bolts (1/2" - 13 x 1 1/2") - replacement part 93892.