

K2-631G Catch Basin

K2-631G Catch Basin

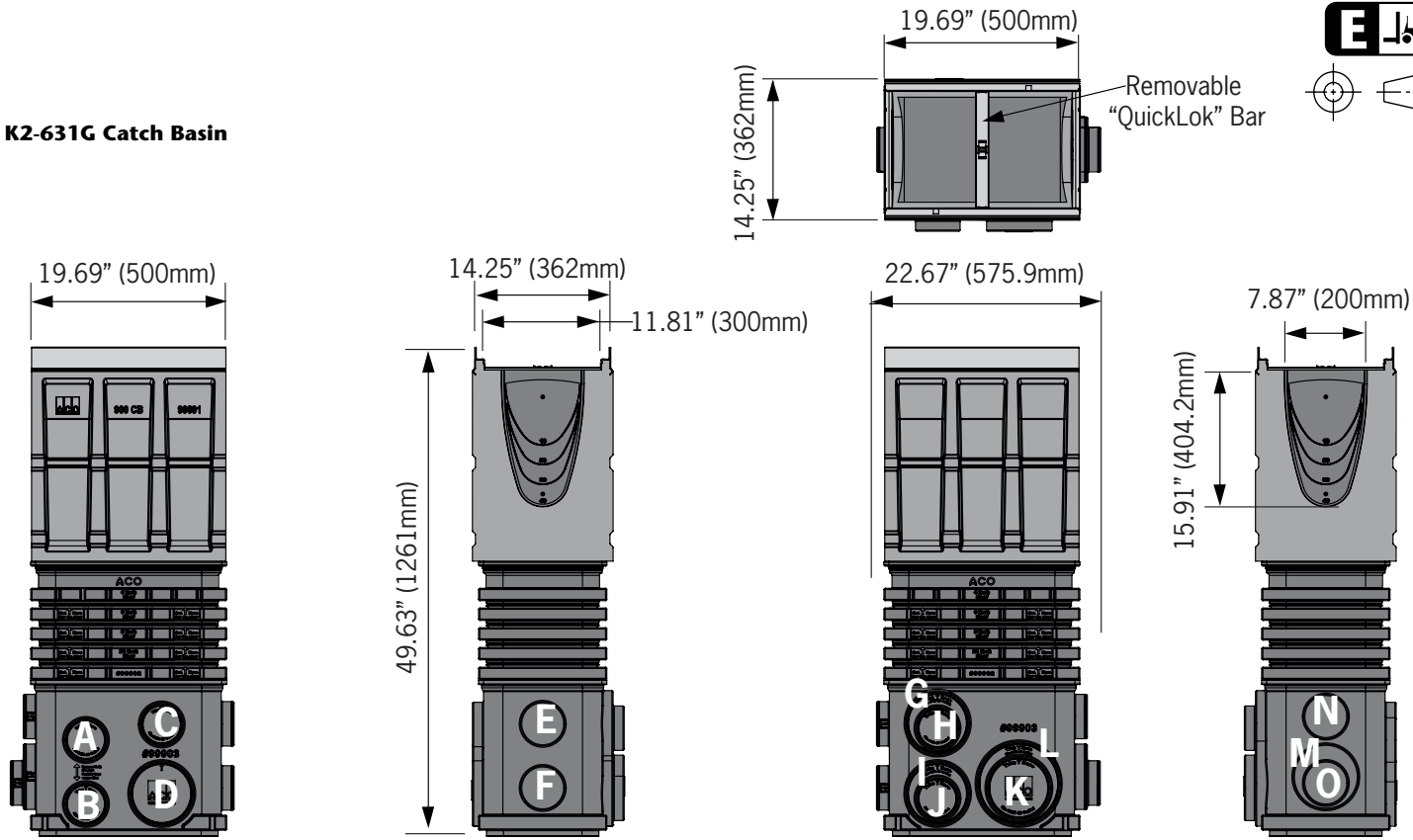

Outlet flow rates

Outlet	Product	Outlet size (Sch. 40)	Invert Depth	GPM	CFS
A	Type K2-631G	4" round	41.80"	343	0.77
B	Type K2-631G	4" round	48.29"	370	0.83
C	Type K2-631G	4" round	40.22"	337	0.75
D	Type K2-631G	6" round	48.29"	824	1.84
E	Type K2-631G	4" round	40.37"	337	0.75
F	Type K2-631G	4" round	46.87"	365	0.81
G	Type K2-631G	6" round	41.15"	757	1.69
H	Type K2-631G	4" round	40.59"	338	0.75
I	Type K2-631G	6" round	48.28"	824	1.84
J	Type K2-631G	4" round	47.72"	368	0.82
K	Type K2-631G	6" round	47.72"	819	1.83
L	Type K2-631G	8" round	48.28"	1449	3.23
M	Type K2-631G	6" round	46.78"	810	1.81
N	Type K2-631G	4" round	39.65"	334	0.74
O	Type K2-631G	4" round	46.36"	363	0.81

Note:

- These are the pipe flow rates at the specified outlet, **NOT** channel flow rates.
*Flow rates without trash bucket - using trash bucket or filter bag reduces flow rates.
- 4" diameter foul air trap, part# 90854, can be fitted to catch basin base at outlet positions A/B and E/F.
- Riser can be cut down in 1" increments.
- Fits KlassikDrain K200 systems

Trash Bucket

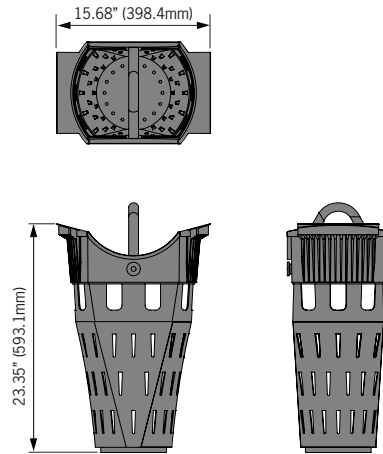

Note: Openings in trash bucket are 74.4"² (48,028mm²)

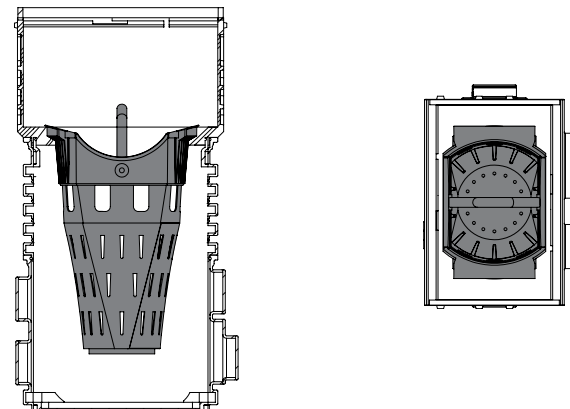

Note: Trash bucket position within K2-631G catch basin body and base

ACO Specification Information

ACO DRAIN

K2-631G Catch Basin



ACO Specification Information

Description	Part No.	Invert Depth		Weight lbs.
		inches	mm	
Type K2-631G Catch basin assembly - top, removable "QuickLok" bar, riser, trash bucket & base	94633	37.40	950	101.0
Catch Basin Components				
Foul air trap - fits both Type 900 & Type 600 basins	90854	-	-	1.2
QuickLok grate removal tool	01318	-	-	0.3

Specifications		General	
Water absorption	0.07%	The catch basin shall be ACO Drain K2-631G Catch Basin - comprising of top section, riser, trash bucket and base as manufactured by ACO, Inc. or similar approved.	
Frost proof	YES	The top unit body shall be manufactured from polyester polymer concrete with minimum properties as follows:	
Salt proof	YES	Compressive strength: 14,000 psi	
Dilute acid and alkali resistant	YES	Flexural strength: 4,000 psi	
The nominal clear opening shall be 14.25" (362mm) wide by 19.69" (500mm) long. Overall width of 22.67" (575.9mm) by 49.63" (1261mm) long. Type K2-631G catch basin assembly has overall depth of 49.63" (1261mm). Polymer concrete top units shall incorporate a cast in galvanized steel frame manufactured with drillouts for channel connection and have a wall thickness of at least 0.59" (15mm). Top units shall have horizontal cast in anchoring key features on the outside to ensure maximum mechanical bond to the surrounding bedding material		and pavement surface. The base and riser unit shall be a LLDPE plastic molding and incorporate molded plastic pipe stubbs to facilitate pipe connection.	
		Grates Grates shall be specified. See separate ACO Spec Info grate sheets for details. After removal of grates and 'QuickLok' bar there shall be uninterrupted access to the catch basin to aid maintenance.	
		Installation The trench drain/catch basin system shall be installed in accordance with the manufacturer's installation instructions and recommendations.	

ACO, Inc.
Northeast Sales Office
 9470 Pinecone Drive
 Mentor, OH 44060
 Tel: (440) 639-7230
 Toll free: (800) 543-4764
 Fax: (440) 639-7235

West Sales Office
 825 W. Beechcraft St.
 Casa Grande, AZ 85122
 Tel: (520) 421-9988
 Toll Free: (888) 490-9552
 Fax: (520) 421-9899

Southeast Sales Office
 4211 Pleasant Road
 Fort Mill, SC 29708
 Toll free: (800) 543-4764
 Fax: (803) 802-1063

Follow us on

Electronic Contact:
 info@ACODrain.us
 www.ACODrain.us



© April 2018, ACO, Inc. This information is believed to be accurate but it is not guaranteed to be so. We cannot assume liability for results that buyer obtains with our product since conditions of use are beyond the control of the company. It is the customer's responsibility to evaluate suitability and safety of product for his own use. ACO, Inc. reserves the right to change the product and specifications without notice.